



BADU[®] STREAM II

Water Treadmill



Complies with UL 1563
Swimming Pool Equipment
Listing #E212148

The Badu[®] Stream Jet System offers many different packages in a wide price range all aimed at pleasing a variety of exercise styles and budgets. The system accommodates installation in limited space and varying pool wall designs.



Features

- A.** Flush mounted jet housing.
- B.** Square anti-entrapment cover provides undetectable pump suction. (8 1/4" x 8 1/4")
- C.** Adjustable water flow jet nozzle.
- D.** Air regulator controls amount of air bubbles in water flow.
- E.** Control box with **GFCI**.
- F.** Speck 4 HP or 3 1/2 HP self-priming, plastic pump, single phase with thermal overload (no motor starter required).
- G.** Pulsating massage hose can be attached to jet nozzle. (optional)

Installation

The **BADU[®] STREAM** is normally incorporated into the original pool design, but it can be added to any pool at a later date.

The **BADU[®] STREAM** has no protruding parts ensuring pool users' safety. Very compact, installs at minimal cost.

All **BADU[®] STREAM** /pump combinations include control box with air button and 50 ft. air tubing. 4" or 3" plumbing is required, depending upon **BADU[®] STREAM** package chosen. Read all instructions before installing.



Two BaduStream jets combined. Illustrated in a wall panel.

INSTALLATION SCHEMATIC

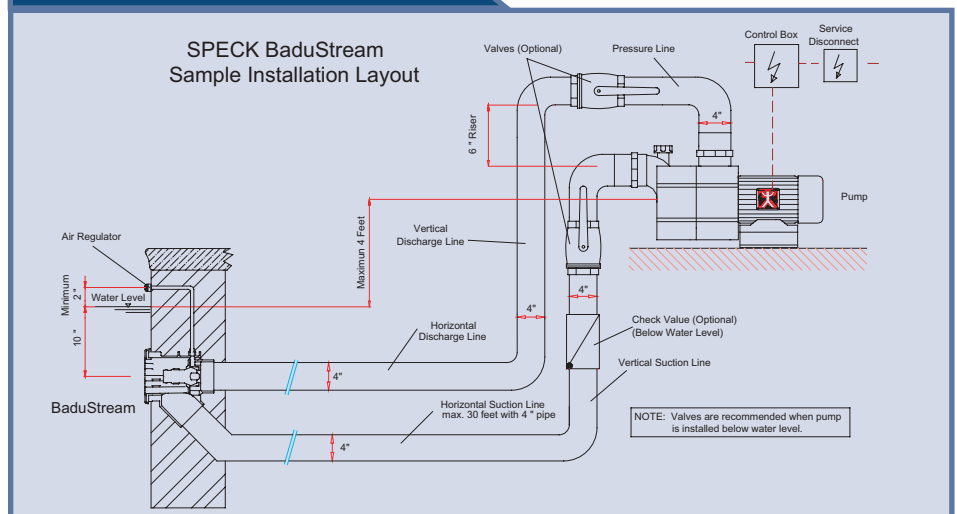

BADU[®] STREAM II Package A

Two **BADU[®] STREAM** Jets complete with one Speck Pump Model 21-80/33, 4 HP, 208-230 Volts, 19A, 400 GPM @ 14 PSI and control box with **GFCI**. The most powerful single pump jet system available providing the recreational swimmer with an intermediate level of exercise. Minimum of 4" plumbing required. **#2308000042**

BADU[®] STREAM II Package B

One **BADU[®] STREAM** Jet complete with one Speck Pump Model 21-80/33, 4 HP, 208-230 Volts, 18.5A, 270 GPM @ 18 PSI and control box with **GFCI**. Same as package A, for swimmers who prefer the economy of single jet operation. Minimum 4" plumbing required. **#2308000040**

BADU[®] STREAM II Package C

One **BADU[®] STREAM** Jet complete with one Speck Pump Model 98-VI, 3 1/2 HP, 208-230 Volts, 13.5A, 180 GPM @ 12 PSI and control box with **GFCI**. Provides a moderate level of exercise for the recreational swimmer. Minimum 3" plumbing required. **#2308000030**

BADU[®] STREAM II Package D

Three **BADU[®] STREAM** Jets combined with two Speck Pump Models 21-80/33, 4 HP, 208-230 Volts, 19A (each), 700 GPM @ 15 PSI and control box with **GFCI**. The most powerful dual pump jet system available providing maximum resistance for the recreational swimmer. Minimum 4" plumbing required. **#2308000046**

Consult your physician before attempting any strenuous exercise. This product may not be challenging or satisfying for all levels of exercise.