

REVISION HISTORY				
REV.	DESCRIPTION	DATE	ECO	BY

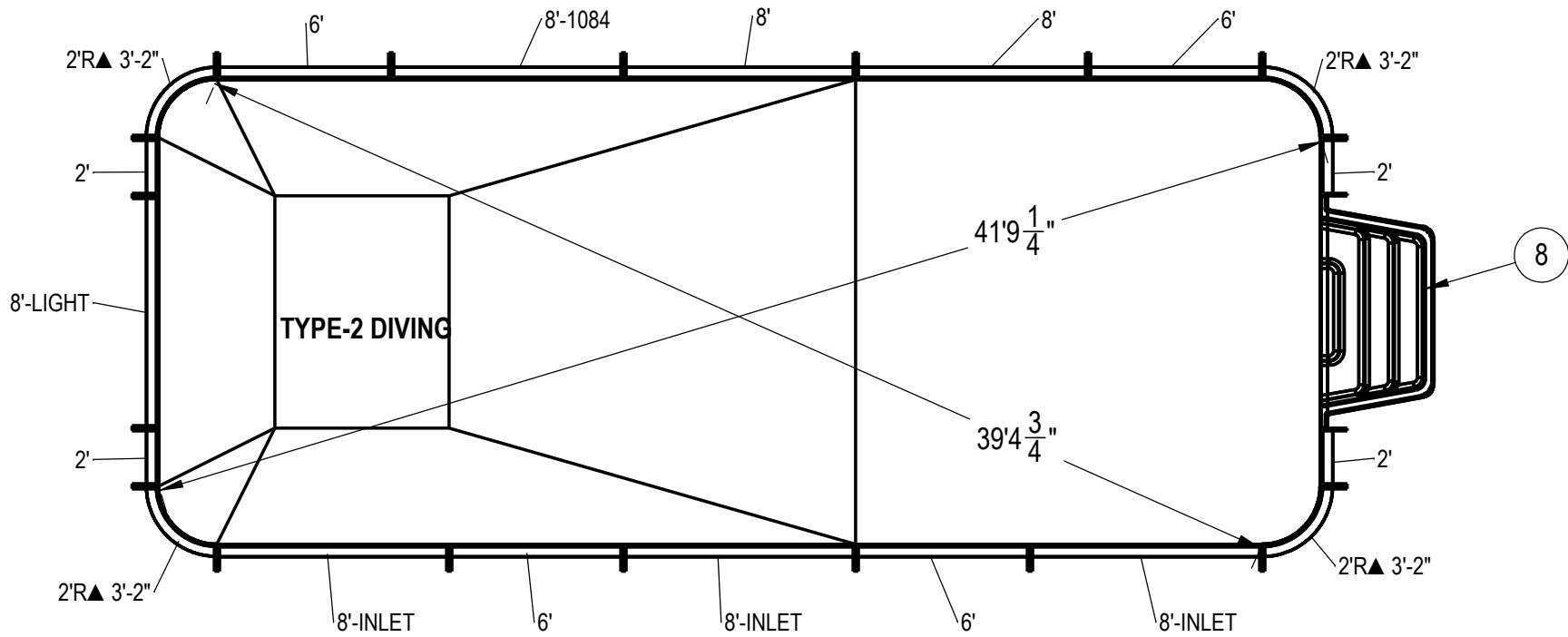

NOTES:

- THESE ARE FINISHED DIMENSIONS READY FOR THE LINER.
- DIMENSIONS ARE FROM INSIDE POOL PANELS.
- ROPE AND FLOAT ASSEMBLY SHOULD BE INSTALLED IN ACCORDANCE WITH CURRENT ANSI/ASPS/ICC REGULATIONS
- HYDRA LINER TRACK FOR STEPS IS INSTALLED WITH THE BARB FACING THE RISER WALL ON THE STEP.

EXCAVATION NOTES:

- ROUGH EXCAVATION SHOULD BE 2" DEEPER IN EACH INSTANCE.
- SOIL TO HAVE MINIMUM BEARING CAPACITY OF 1500 PSF.
- LOCATE TOP OF POOL AT LEAST 6" ABOVE THE SURROUNDING LAND ELEVATION.
- SEE "OVER DIG DETAIL" FOR EXCAVATION AROUND POOL.
- FILL VOIDS UNDER BASE OF PANELS AND TAMP WELL.
- BACK FILL WITH NON-EXPANSIVE MATERIAL.
- FOLLOW ALL CURRENT ANSI / APSP / ICC GUIDELINES FOR RESIDENTIAL POOLS

IMPORTANT NOTES:

THIS DOCUMENT IS FOR ILLUSTRATIVE PURPOSES ONLY. THE DEALER OR CONTRACTOR WHO SELLS OR INSTALLS YOUR POOL IS AN INDEPENDENT CONTRACTOR AND IS NOT AN AGENT OF THE MANUFACTURER. THE CONSTRUCTION METHODS ILLUSTRATED HERE ARE SUGGESTIONS AND APPLY ONLY TO NORMAL GROUND CONDITIONS. THERE MAY BE ADDITIONAL PRECAUTIONS AND/OR METHODS OF CONSTRUCTION. PROPER INSTALLATION IS THE RESPONSIBILITY OF THE DEALER/BUILDER/CONTRACTOR.

ITEM	FILE NAME	DESCRIPTION	CUSTOMER DRAWING #	VENDOR PART #	QTY.
1	PANEL, RADIUS	PANEL, 2' RADIUS, 3-2" LONG, 700 SERIES	HPSE2R	00002541	4
2	PANEL, STRAIGHT	PANEL, 8' LONG, LIGHT, 700 SERIES	HPSE108L	00004962	1
3	PANEL, STRAIGHT	PANEL, 6' LONG, 700 SERIES	HPSE106P	00002731	4
4	PANEL, STRAIGHT	PANEL, 8' LONG, 700 SERIES	HPSE108P	00004961	2
5	PANEL, STRAIGHT	PANEL, 8' LONG, INLET, 700 SERIES	HPSE108I	00004969	3
6	PANEL, STRAIGHT	PANEL, 2' LONG, 700 SERIES	HPSE102P	00005483	4
7	PANEL, STRAIGHT	PANEL, 8' LONG, 1084, 700 SERIES	HPSE10884	00004966	1
8	HS110N	STEP, 8", TWIN SEAT, 4 TREAD	HS110N	HS110N	1
9	SBRACE	BRACE, FOLD OVER WITH TURNBUCKLE, STEEL, HPSFOB	HPSFOB	HPSFOB	20
10	BOLT, PACK	BOLT, FLANGE, 3/8-16 X 1", PACK (50)	HPS1916	HPS1916	5

ENGINEERING DRAWING NUMBER: 00018110	WEIGHT:	UNLESS OTHERWISE SPECIFIED DIMENSIONS ARE IN INCHES TOLERANCES DECIMALS: X ± .1 XX ± .01 XXX ± .001 XXXX ± .0005 ANGULAR: X ± 0.5 THIRD ANGLE PROJECTION
	lbs	
	VOLUME:	
	Inch ³	
	COLOR:	
	HEAT TREAT:	
FINISH:		
TEXTURE:		

DESIGNED BY: BUMPHREY	CREATION DATE: 4/9/2013
DETAILED BY: JRITTENHOUSE	DETAILED DATE: 4/3/2018
LAST REVISED BY: rhouston	LAST REVISED DATE: 4/3/2018
MATERIAL:	

HYDRA POOLS	
TITLE: LAYOUT, 16' X 40', RECTANGLE, 2' RADIUS, 8' DEEP, HS110N, 3-INLETS, 1084, 700 SERIES	
PART NUMBER: 00018110	SCALE: 1:72 SHEET: 1 OF 4 SIZE: A

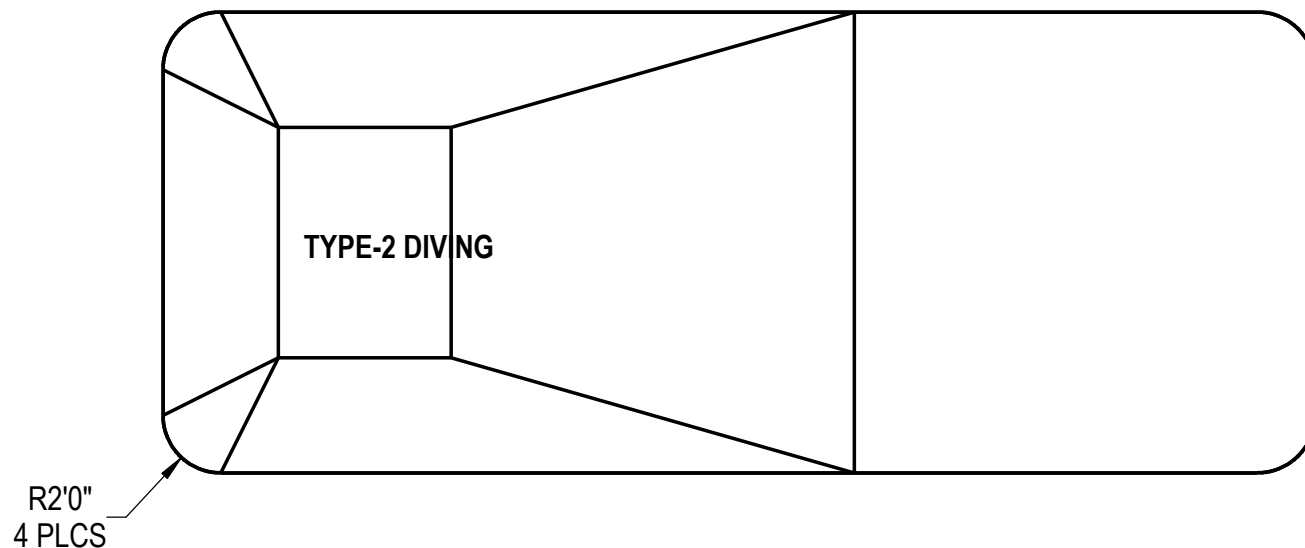
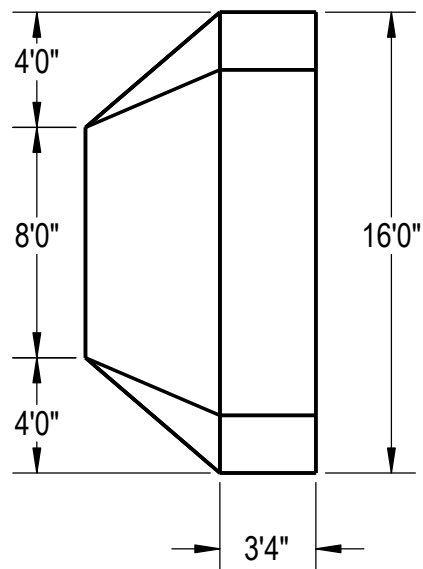

Area: 636.57ft ^2
Perimeter: 108.57ft
Volume = 22555 US gallons

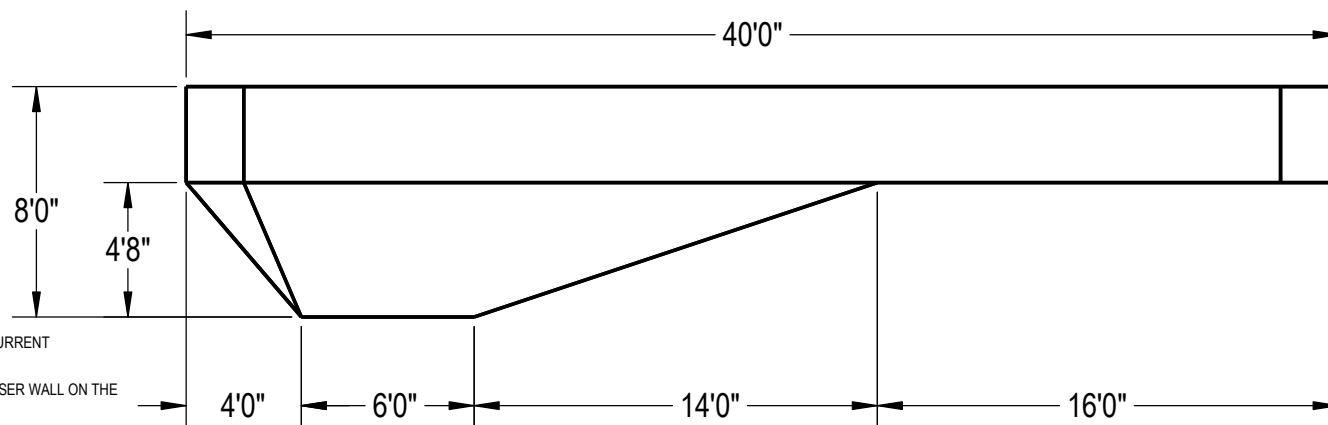

NOTES:

1. THESE ARE FINISHED DIMENSIONS READY FOR THE LINER.
2. DIMENSIONS ARE FROM INSIDE POOL PANELS.
3. ROPE AND FLOAT ASSEMBLY SHOULD BE INSTALLED IN ACCORDANCE WITH CURRENT ANSI/ASPS/ICC REGULATIONS
4. HYDRA LINER TRACK FOR STEPS IS INSTALLED WITH THE BARB FACING THE RISER WALL ON THE STEP.

EXCAVATION NOTES:

5. ROUGH EXCAVATION SHOULD BE 2" DEEPER IN EACH INSTANCE.
6. SOIL TO HAVE MINIMUM BEARING CAPACITY OF 1500 PSF.
7. LOCATE TOP OF POOL AT LEAST 6" ABOVE THE SURROUNDING LAND ELEVATION.
8. SEE "OVER DIG DETAIL" FOR EXCAVATION AROUND POOL.
9. FILL VOIDS UNDER BASE OF PANELS AND TAMP WELL.
10. BACK FILL WITH NON-EXPANSIVE MATERIAL.
11. FOLLOW ALL CURRENT ANSI / APSP / ICC GUIDELINES FOR RESIDENTIAL POOLS

IMPORTANT NOTES:

THIS DOCUMENT IS FOR ILLUSTRATIVE PURPOSES ONLY. THE DEALER OR CONTRACTOR WHO SELLS OR INSTALLS YOUR POOL IS AN INDEPENDENT CONTRACTOR AND IS NOT AN AGENT OF THE MANUFACTURER. THE CONSTRUCTION METHODS ILLUSTRATED HERE ARE SUGGESTIONS AND APPLY ONLY TO NORMAL GROUND CONDITIONS. THERE MAY BE ADDITIONAL PRECAUTIONS AND/OR METHODS OF CONSTRUCTION. PROPER INSTALLATION IS THE RESPONSIBILITY OF THE DEALER/BUILDER/CONTRACTOR.

ENGINEERING DRAWING NUMBER: 00018110	WEIGHT:	UNLESS OTHERWISE SPECIFIED DIMENSIONS ARE IN INCHES TOLERANCES DECIMALS: X ± .1 XX ± .01 XXX ± .001 XXXX ± .0005 ANGULAR: X ± 0.5 THIRD ANGLE PROJECTION	DESIGNED BY:	CREATION DATE:	HYDRA POOLS
	lbs		BUMPHREY	4/9/2013	
	VOLUME:		DETAILED BY:	DETAILED DATE:	
	Inch ³		JRITTENHOUSE	4/3/2018	
	COLOR:		LAST REVISED BY:	LAST REVISED DATE:	
NA	rhouston	4/3/2018	TITLE:	LAYOUT, 16' X 40', RECTANGLE, 2' RADIUS, 8' DEEP, HS110N, 3-INLETS, 1084, 700 SERIES	
HEAT TREAT:	MATERIAL:		PART NUMBER:	00018110	
NA			SCALE:	1:128	SIZE:
FINISH:			SHEET:	2 OF 4	A
NA					
TEXTURE:					
NA					

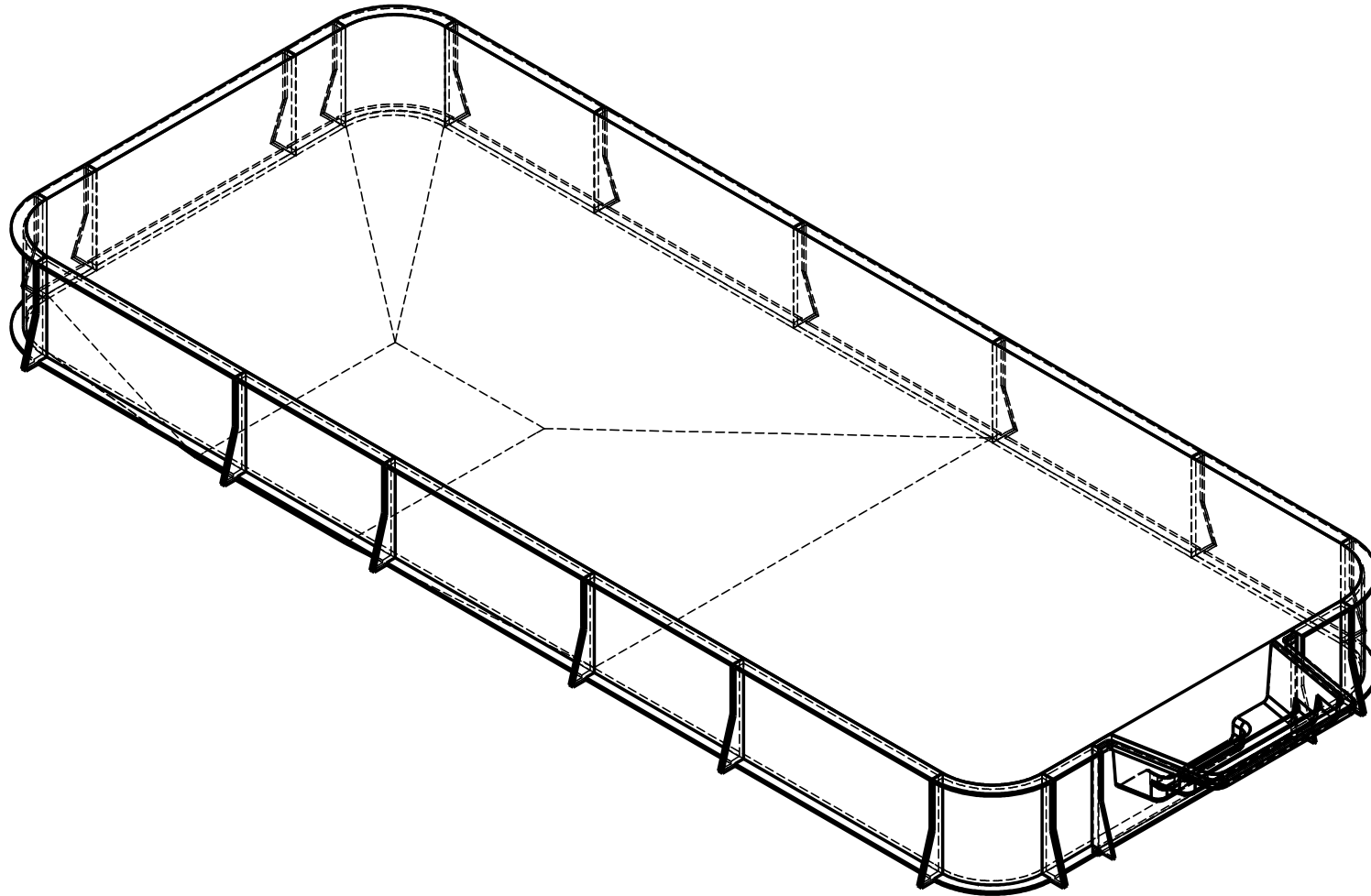

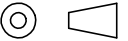
ENGINEERING DRAWING NUMBER: 00018110	WEIGHT:	UNLESS OTHERWISE SPECIFIED DIMENSIONS ARE IN INCHES TOLERANCES DECIMALS: X ± .1 XX ± .01 XXX ± .001 XXXX ± .0005 ANGULAR: X ± 0.5 THIRD ANGLE PROJECTION 	DESIGNED BY:	CREATION DATE:	HYDRA POOLS	
	lbs		BUMPHREY	4/9/2013		
	VOLUME:		Detailed by:	DETAILED DATE:	TITLE: LAYOUT, 16' X 40', RECTANGLE, 2' RADIUS, 8' DEEP, HS110N, 3-INLETS, 1084, 700 SERIES	
	Inch ³		JRITTENHOUSE	4/3/2018		
	COLOR:		LAST REVISED BY:	LAST REVISED DATE:	PART NUMBER: 00018110	
	HEAT TREAT:		rhouston	4/3/2018		
FINISH:	MATERIAL:		1:60	A		
TEXTURE:			SHEET:			
			3 OF 4			

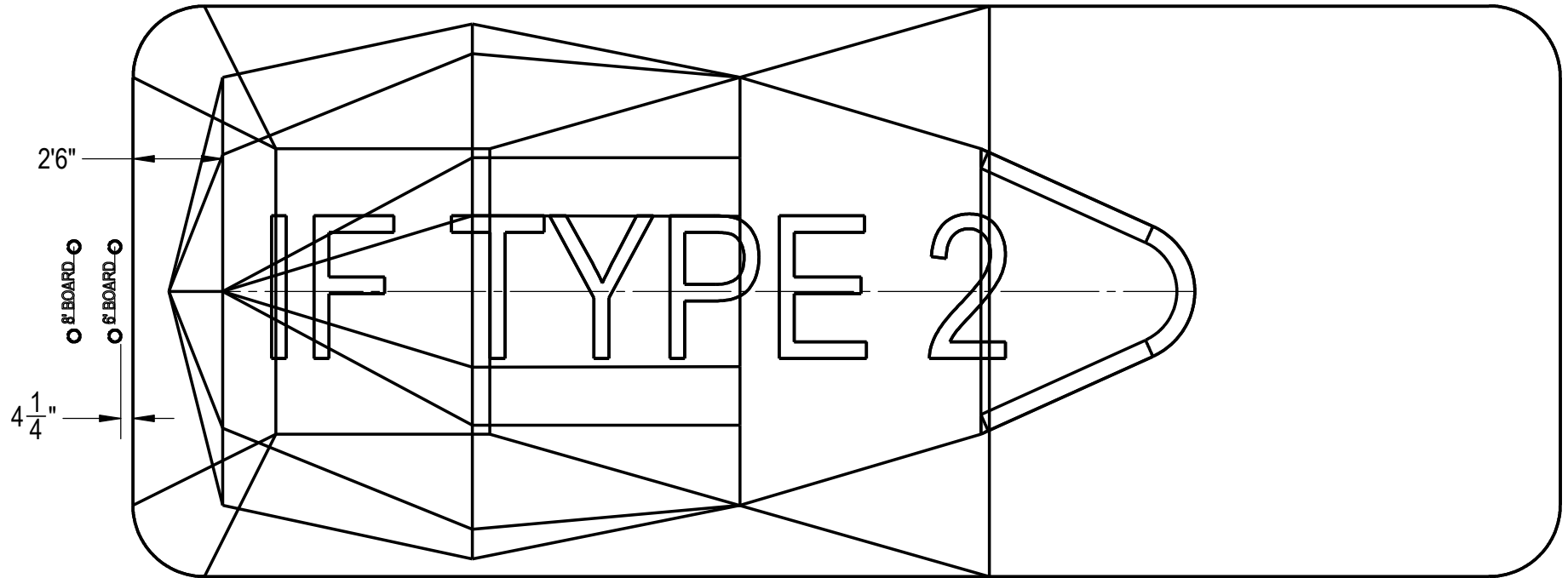

ENGINEERING DRAWING NUMBER: 00018110	WEIGHT:	UNLESS OTHERWISE SPECIFIED DIMENSIONS ARE IN INCHES TOLERANCES DECIMALS: X ± .1 XX ± .01 XXX ± .001 XXXX ± .0005 ANGULAR: X ± 0.5 THIRD ANGLE PROJECTION 	DESIGNED BY:	CREATION DATE:	HYDRA POOLS TITLE: LAYOUT, 16' X 40', RECTANGLE, 2' RADIUS, 8" DEEP, HS110N, 3-INLETS, 1084, 700 SERIES	
	lbs		BUMPHREY	4/9/2013		
	VOLUME:		DETAILED BY:	DETAILED DATE:		
	Inch ³		JRITTENHOUSE	4/3/2018	PART NUMBER:	00018110
	COLOR:		LAST REVISED BY:	LAST REVISED DATE:		
	HEAT TREAT:		rhouston	4/3/2018	1:60	A
FINISH:	MATERIAL:		SHEET:			
TEXTURE:			4 OF 4			