

REVISION HISTORY				
REV.	DESCRIPTION	DATE	ECO	BY

MIRROR NUMBER: 00018116
CHECK IN DATE/TIME: Wednesday, April 04, 2018 7:09:38 AM

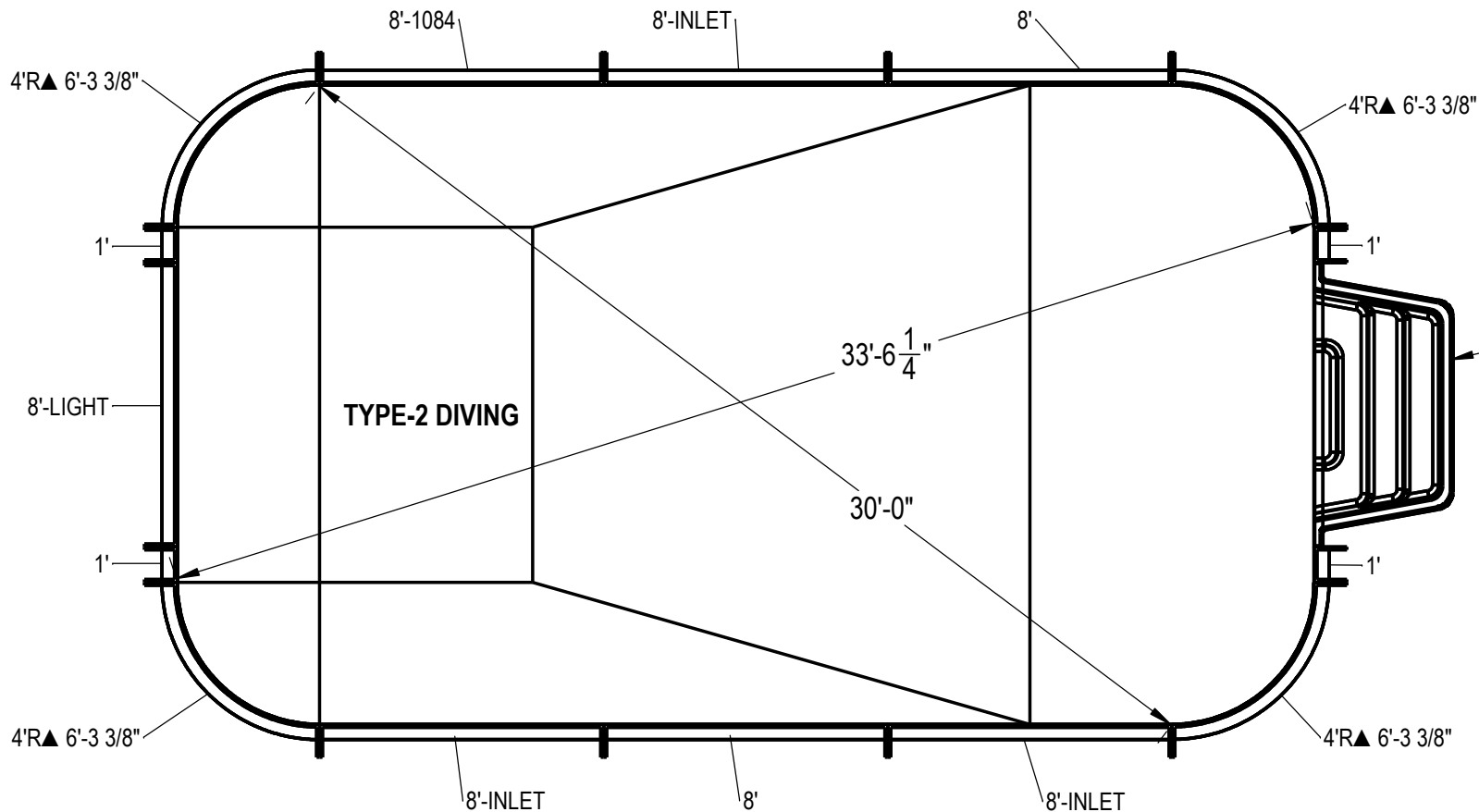

NOTES:

- THESE ARE FINISHED DIMENSIONS READY FOR THE LINER.
- DIMENSIONS ARE FROM INSIDE POOL PANELS.
- ROPE AND FLOAT ASSEMBLY SHOULD BE INSTALLED IN ACCORDANCE WITH CURRENT ANSI/ASPS/ICC REGULATIONS
- HYDRA LINER TRACK FOR STEPS IS INSTALLED WITH THE BARB FACING THE RISER WALL ON THE STEP.

EXCAVATION NOTES:

- ROUGH EXCAVATION SHOULD BE 2" DEEPER IN EACH INSTANCE.
- SOIL TO HAVE MINIMUM BEARING CAPACITY OF 1500 PSF.
- LOCATE TOP OF POOL AT LEAST 6" ABOVE THE SURROUNDING LAND ELEVATION.
- SEE "OVER DIG DETAIL" FOR EXCAVATION AROUND POOL.
- FILL VOIDS UNDER BASE OF PANELS AND TAMP WELL.
- BACK FILL WITH NON-EXPANSIVE MATERIAL.
- FOLLOW ALL CURRENT ANSI / APSP / ICC GUIDELINES FOR RESIDENTIAL POOLS

IMPORTANT NOTES:

THIS DOCUMENT IS FOR ILLUSTRATIVE PURPOSES ONLY. THE DEALER OR CONTRACTOR WHO SELLS OR INSTALLS YOUR POOL IS AN INDEPENDENT CONTRACTOR AND IS NOT AN AGENT OF THE MANUFACTURER. THE CONSTRUCTION METHODS ILLUSTRATED HERE ARE SUGGESTIONS AND APPLY ONLY TO NORMAL GROUND CONDITIONS. THERE MAY BE ADDITIONAL PRECAUTIONS AND/OR METHODS OF CONSTRUCTION. PROPER INSTALLATION IS THE RESPONSIBILITY OF THE DEALER/BUILDER/CONTRACTOR.

ITEM	FILE NAME	DESCRIPTION	CUSTOMER DRAWING #	VENDOR PART #	QTY.
1	PANEL, RADIUS	PANEL, 4' RADIUS, 6'-3 3/8" LONG, 700 SERIES	HPSE4R	00002458	4
2	PANEL, STRAIGHT	PANEL, 8' LONG, LIGHT, 700 SERIES	HPSE108L	00004962	1
3	PANEL, STRAIGHT	PANEL, 8' LONG, INLET, 700 SERIES	HPSE108I	00004969	3
4	PANEL, STRAIGHT	PANEL, 8' LONG, 1084, 700 SERIES	HPSE10884	00004966	1
5	PANEL, STRAIGHT	PANEL, 8' LONG, 700 SERIES	HPSE108P	00004961	2
6	PANEL, STRAIGHT	PANEL, 1' LONG, 700 SERIES	HPSE101P	00002469	4
7	HS110N	STEP, 8', TWIN SEAT, 4 TREAD	HS110N	HS110N	1
8	SBRACE	BRACE, FOLD OVER WITH TURNBUCKLE, STEEL, HPSFOB	HPSFOB	HPSFOB	16
9	BOLT, PACK	BOLT, FLANGE, 3/8-16 X 1", PACK (50)	HPS1916	HPS1916	4

ENGINEERING DRAWING NUMBER: 00018116	WEIGHT:	UNLESS OTHERWISE SPECIFIED DIMENSIONS ARE IN INCHES TOLERANCES DECIMALS: X ± .1 XX ± .01 XXX ± .001 XXXX ± .0005 ANGULAR: X ± 0.5 THIRD ANGLE PROJECTION
	VOLUME:	
	Color:	
	HEAT TREAT:	
	FINISH:	
	TEXTURE:	

DESIGNED BY: BUMPHREY	CREATION DATE: 4/9/2013
DETAILED BY: JRITTENHOUSE	DETAILED DATE: 4/4/2018
LAST REVISED BY: rhouston	LAST REVISED DATE: 4/4/2018
MATERIAL:	

HYDRA POOLS

TITLE: LAYOUT, 18' X 32' RECTANGLE, 4' RADIUS, 8' DEEP, HS110N, LIGHT, 1084, 3-INLET, 700 SERIES

PART NUMBER: **00018116**

SCALE: 1:72
SHEET: 1 OF 4
SIZE: A

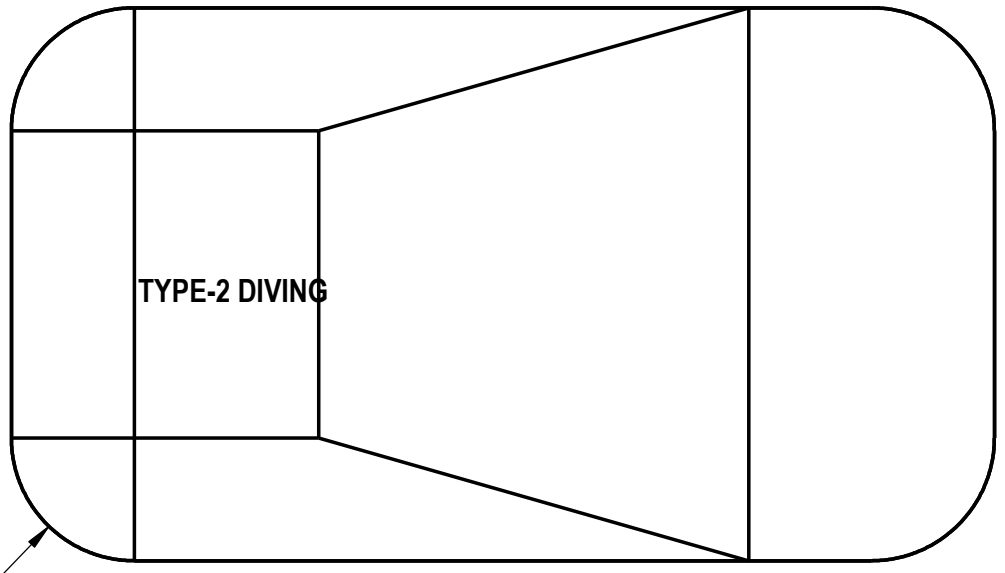
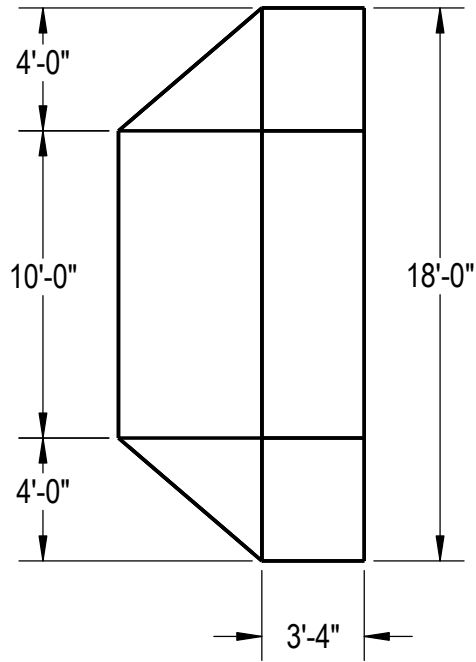

R4'-0"
4 PLCS

Area: 562.27ft ^2
Perimeter: 93.13ft
Volume = 21690 US gallons

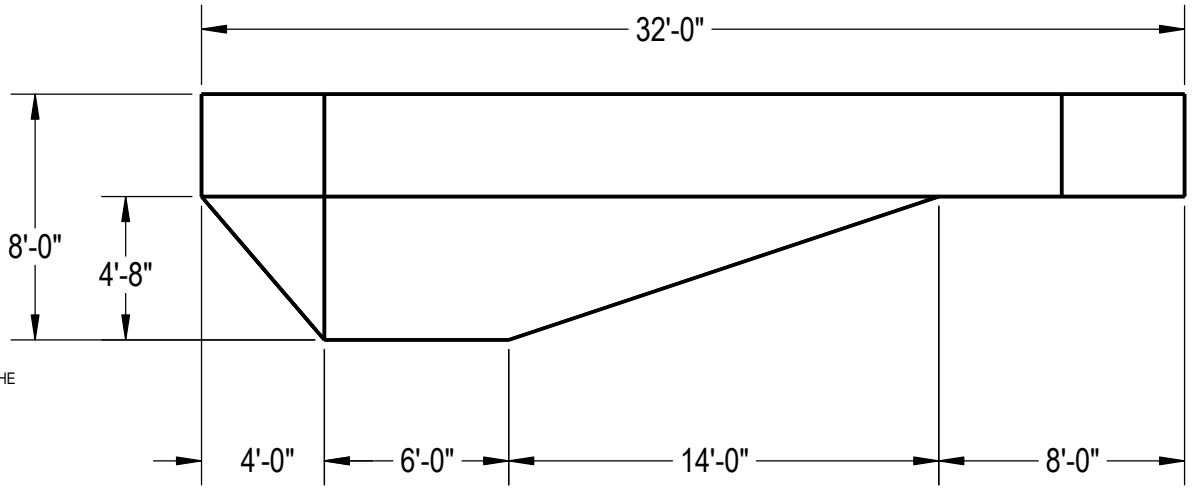

NOTES:

1. THESE ARE FINISHED DIMENSIONS READY FOR THE LINER.
2. DIMENSIONS ARE FROM INSIDE POOL PANELS.
3. ROPE AND FLOAT ASSEMBLY SHOULD BE INSTALLED IN ACCORDANCE WITH CURRENT ANSI/ASPS/ICC REGULATIONS
4. HYDRA LINER TRACK FOR STEPS IS INSTALLED WITH THE BARB FACING THE RISER WALL ON THE STEP.

EXCAVATION NOTES:

5. ROUGH EXCAVATION SHOULD BE 2" DEEPER IN EACH INSTANCE.
6. SOIL TO HAVE MINIMUM BEARING CAPACITY OF 1500 PSF.
7. LOCATE TOP OF POOL AT LEAST 6" ABOVE THE SURROUNDING LAND ELEVATION.
8. SEE "OVER DIG DETAIL" FOR EXCAVATION AROUND POOL.
9. FILL VOIDS UNDER BASE OF PANELS AND TAMP WELL.
10. BACK FILL WITH NON-EXPANSIVE MATERIAL.
11. FOLLOW ALL CURRENT ANSI / APSP / ICC GUIDELINES FOR RESIDENTIAL POOLS

IMPORTANT NOTES:

THIS DOCUMENT IS FOR ILLUSTRATIVE PURPOSES ONLY. THE DEALER OR CONTRACTOR WHO SELLS OR INSTALLS YOUR POOL IS AN INDEPENDENT CONTRACTOR AND IS NOT AN AGENT OF THE MANUFACTURER. THE CONSTRUCTION METHODS ILLUSTRATED HERE ARE SUGGESTIONS AND APPLY ONLY TO NORMAL GROUND CONDITIONS. THERE MAY BE ADDITIONAL PRECAUTIONS AND/OR METHODS OF CONSTRUCTION. PROPER INSTALLATION IS THE RESPONSIBILITY OF THE DEALER/BUILDER/CONTRACTOR.

ENGINEERING DRAWING NUMBER: 00018116	WEIGHT:	UNLESS OTHERWISE SPECIFIED DIMENSIONS ARE IN INCHES TOLERANCES DECIMALS: X ± .1 XX ± .01 XXX ± .001 XXXX ± .0005 ANGULAR: X ± 0.5 THIRD ANGLE PROJECTION 	DESIGNED BY:	CREATION DATE:	HYDRA POOLS TITLE: LAYOUT, 18' X 32' RECTANGLE, 4' RADIUS, 8' DEEP, HS110N, LIGHT, 1084, 3-INLET, 700 SERIES
	VOLUME:		BUMPHREY	4/9/2013	
	Inch ³		DETAILED BY:	DETAILED DATE:	
	COLOR:		JRITTENHOUSE	4/4/2018	
NA	HEAT TREAT:	LAST REVISED BY:	LAST REVISED DATE:	PART NUMBER:	SCALE: 1:84 SHEET: 2 OF 4 SIZE: A
NA	FINISH:	rhouston	4/4/2018	00018116	
NA	TEXTURE:	MATERIAL:			

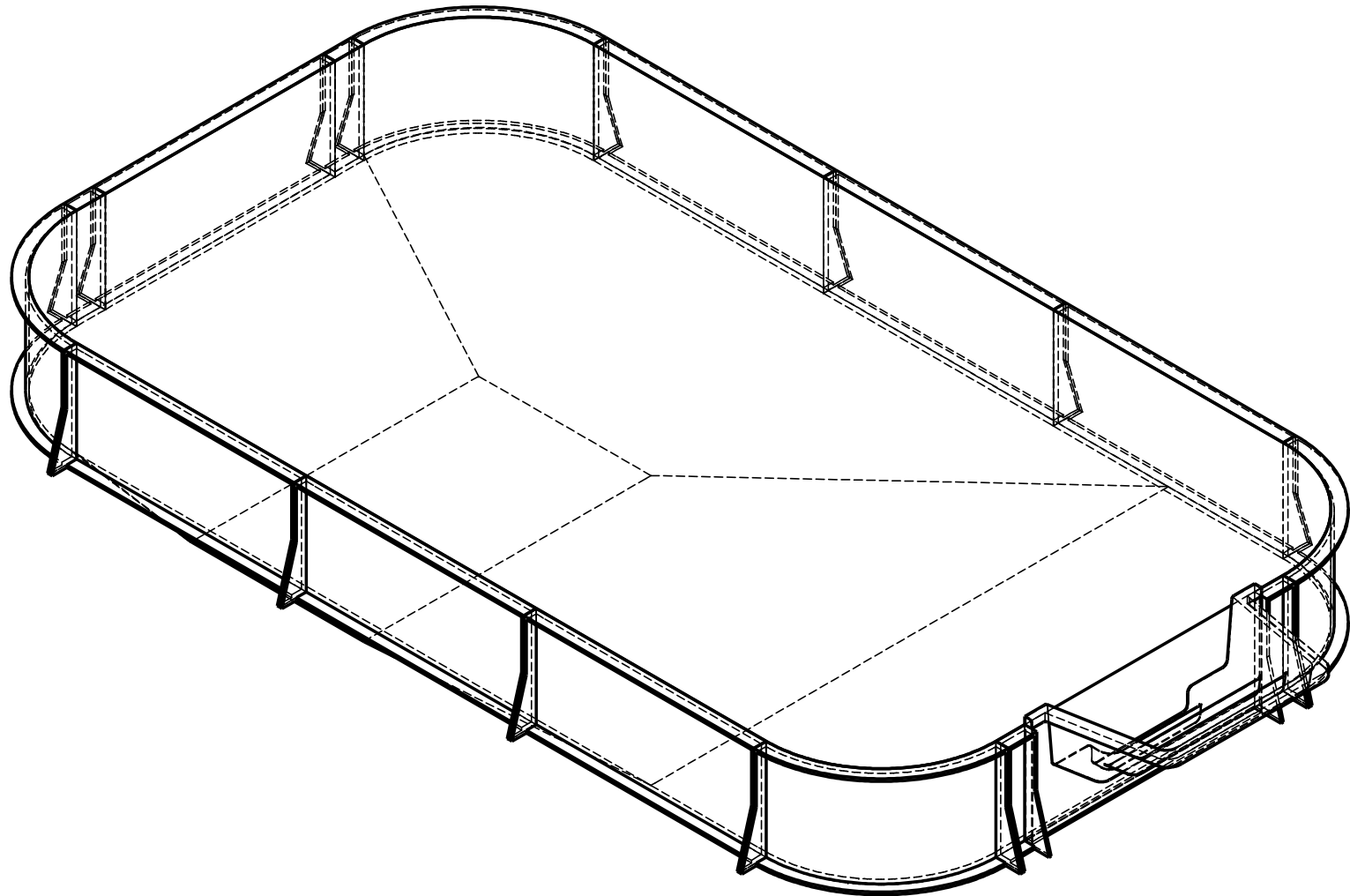

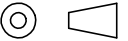
ENGINEERING DRAWING NUMBER: 00018116	WEIGHT:	UNLESS OTHERWISE SPECIFIED DIMENSIONS ARE IN INCHES TOLERANCES DECIMALS: X ± .1 XX ± .01 XXX ± .001 XXXX ± .0005 ANGULAR: X ± 0.5 THIRD ANGLE PROJECTION 	DESIGNED BY:	CREATION DATE:	HYDRA POOLS	
	lbs		BUMPHREY	4/9/2013		
	VOLUME:		DETAILED BY:	DETAILED DATE:	TITLE: LAYOUT, 18' X 32' RECTANGLE, 4' RADIUS, 8' DEEP, HS110N, LIGHT, 1084, 3-INLET, 700 SERIES	
	Inch ³		JRITTENHOUSE	4/4/2018		
	COLOR:		LAST REVISED BY:	LAST REVISED DATE:	PART NUMBER: 00018116	
	HEAT TREAT:		rhouston	4/4/2018		
FINISH:	MATERIAL:		1:72	A		
TEXTURE:			SHEET:			
			3 OF 4			

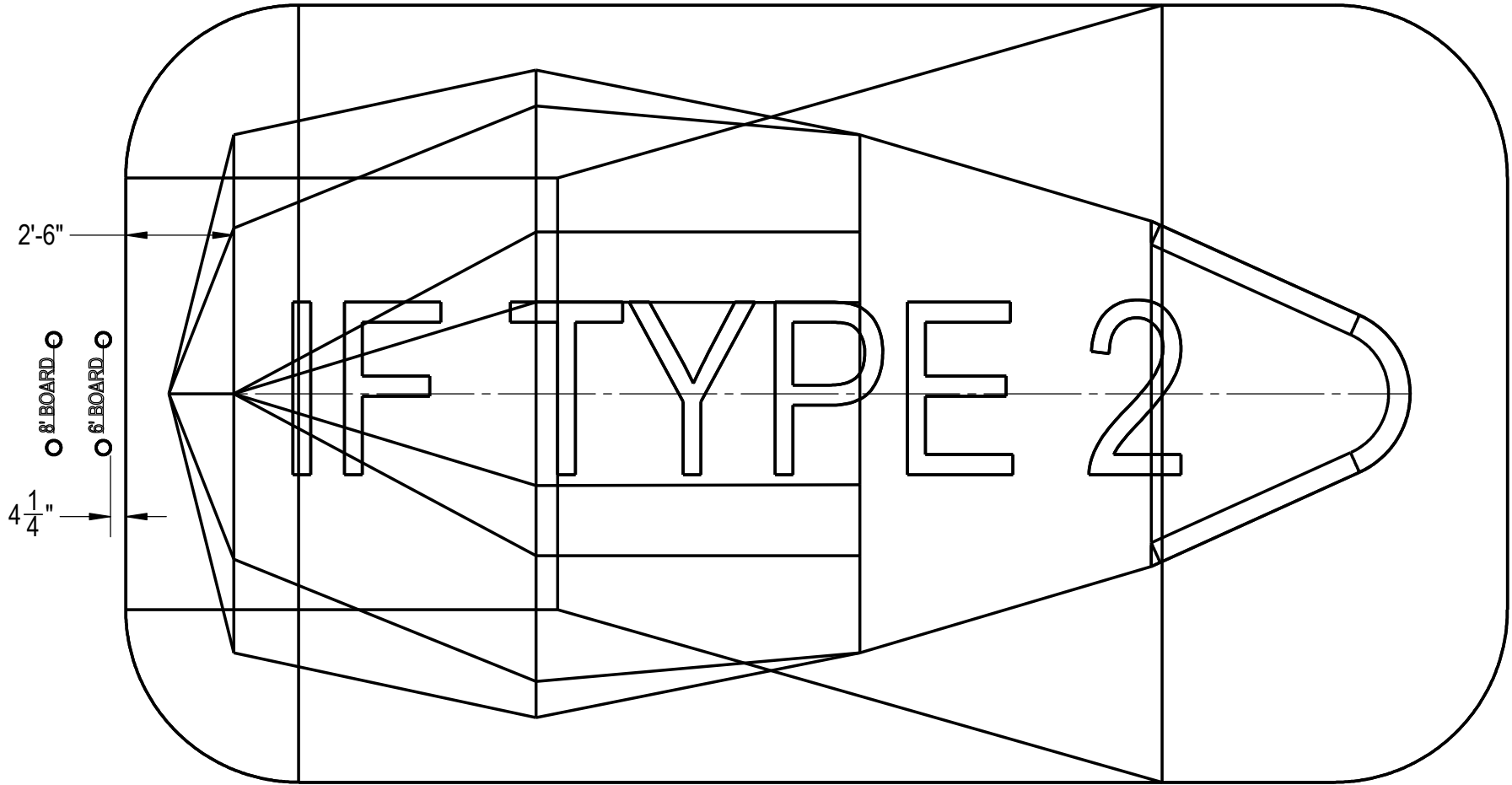

ENGINEERING DRAWING NUMBER: 00018116	WEIGHT:	UNLESS OTHERWISE SPECIFIED DIMENSIONS ARE IN INCHES TOLERANCES DECIMALS: X ± .1 XX ± .01 XXX ± .001 XXXX ± .0005 ANGULAR: X ± 0.5 THIRD ANGLE PROJECTION 	DESIGNED BY:	CREATION DATE:	HYDRA POOLS	
	lbs		BUMPHREY	4/9/2013		
	VOLUME:		DETAILED BY:	DETAILED DATE:		
	Inch ³		JRITTENHOUSE	4/4/2018	TITLE:	LAYOUT, 18' X 32' RECTANGLE, 4' RADIUS, 8' DEEP, HS110N, LIGHT, 1084, 3-INLET, 700 SERIES
	COLOR:		LAST REVISED BY:	LAST REVISED DATE:	PART NUMBER:	
	HEAT TREAT:		rhouston	4/4/2018	00018116	SCALE:
FINISH:	MATERIAL:			1:72	A	
TEXTURE:				SHEET:		
				4 OF 4		