

BOOST-RITE® BOOSTER PUMP



ADVANCED IMPELLER TECHNOLOGY CUTS PRESSURE-SIDE CLEANING COSTS BY OVER 25%*

Pressure-side pool cleaning just got a whole lot less expensive thanks to the NEW, eco-friendly Boost-Rite pump from Pentair. This innovative design saves pool owners more than 25%* in energy costs over other booster pumps on the market. With an advanced 5-stage impeller design, the Boost-Rite pump delivers greater water pressure for more powerful and efficient cleaning... at significantly less cost.

Power up your pressure-side cleaner now with a Boost-Rite pump. You'll save money with every cleaning—and enjoy all the performance your pool cleaner was designed to give you.



ENERGY USAGE COMPARISON

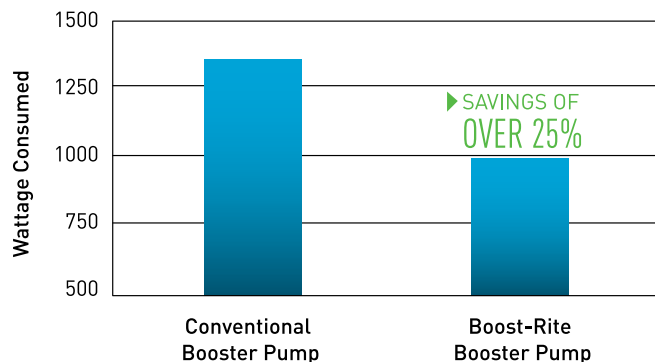

AN ECO SELECT® BRAND PRODUCT

The Boost-Rite pump has earned the Eco Select brand distinction as one of the "greenest" and most efficient choices from Pentair. Eco Select products are designed to help you save energy, conserve water, eliminate or reduce noise, or otherwise contribute to a more environmentally responsible equipment system.



*Actual energy usage may vary based upon plumbing size and length and other hydraulic factors.

BOOST-RITE[®]

BOOSTER PUMP

Powerful 5-stage impeller design cuts operating costs by over 25%*

1" fittings are 75% larger in area, for better flow and greater efficiency

Totally Enclosed Fan Cooled (TEFC) motor design allows the pump to run cooler and quieter

Condensed size is 1/3 smaller than competing pumps, taking up less space on the equipment pad

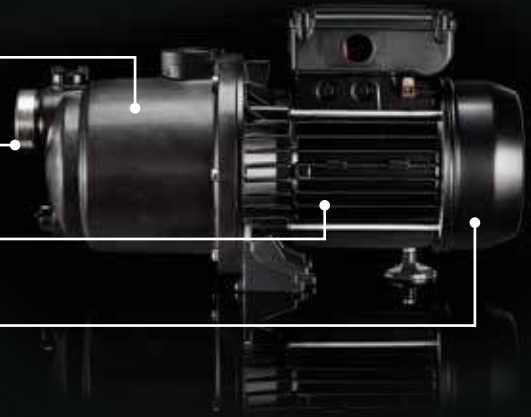

ENGINEERED FOR SUPERIOR ALL-AROUND PERFORMANCE

The Boost-Rite pump delivers more of what you want—lower energy consumption, top performance, easier installation, quieter operation, and greater durability.

- **Lower energy consumption:** Advanced 5-stage impeller design cuts electricity use by over 25%*, offering you substantial savings.
- **Easier installation:** 1/3 smaller than other pumps so it's easier to handle and plumb, yet thoughtfully includes a larger wiring compartment for easier access.
- **Quieter operation:** For a more relaxing poolside experience.
- **Greater durability:** Totally Enclosed Fan Cooled (TEFC) motor runs cooler for longer pump life.
- **More power:** The Boost-Rite pump delivers greater water pressure for more powerful cleaning...at less cost.
- UL and cUL Listed for safety.

AVAILABLE FROM:

PERFORMANCE CURVE

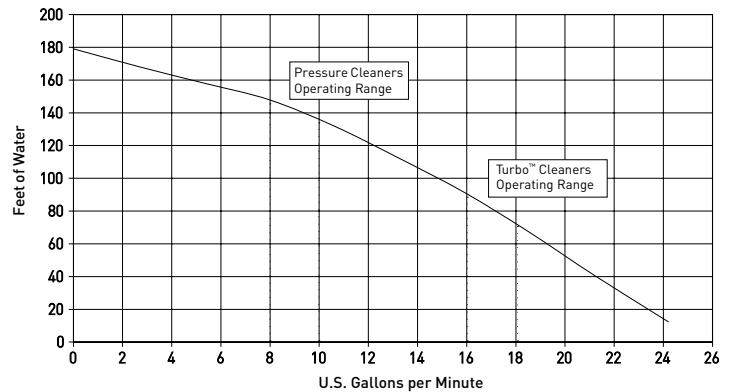

1620 HAWKINS AVE, SANFORD, NC 27330 800.831.7133 WWW.PENTAIRPOOL.COM

All Pentair trademarks and logos are owned by Pentair or one of its global affiliates. Boost-Rite[®] and Eco Select[®] are registered trademarks of Pentair Water Pool and Spa, Inc. and/or its affiliated companies in the United States and/or other countries. Because we are continuously improving our products and services, Pentair reserves the right to change specifications without prior notice. Pentair is an equal opportunity employer.

pumps • filters • heaters • heat pumps • automation • lighting • cleaners • sanitizers • water features • maintenance products

4/16 Part # P1-128 ©2016 Pentair Water Pool and Spa, Inc. All rights reserved.

