



Drain Pump Kit for Undercounter Clear Ice Maker

For use with H50IM Series Clear Ice Makers

Check to ensure all parts are included:

Index No.	Description	Qty.
1	Drain Pump Assembly	1
2	Vinyl Hose (drain hose) (5/8" ID x 6.5")	1
3	Vinyl Hose (drain hose) (3/8" ID x 27.5")	1
4	High Pressure Clear PVC Hose (discharge hose) (1/2" I.D.x 10')	1
5	Small Clamp (vent hose to drain pump)	1
6	Medium Clamp (discharge hose to drain pump)	1
7	Large Clamp (drain hose/drain elbow to ice maker and drain pump)	2
8	Hose Clips (vent hose)	2
8a	Truss Head Screw (4x8, SS)	2

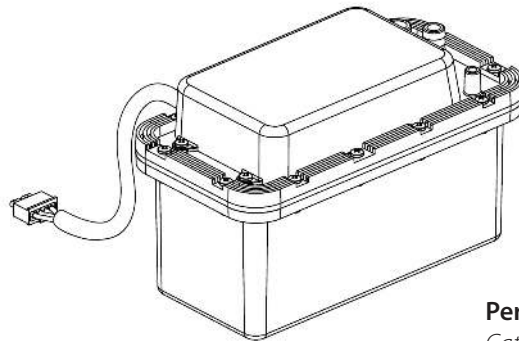

Perlick Drain Pump

Catalog No. 63802A (Part No. HS-5061)

⚠ WARNING

- Only qualified service technicians should install and service this drain pump to reduce the risk of death, electric shock, serious injury or fire. A plumbing permit and the services of a licensed plumber may be required in some areas.
- No installation or service should be undertaken until the technician has thoroughly read these instructions. Failure to install, prime, operate, and maintain this drain pump in accordance with these instructions will adversely affect safety, performance, component life, and warranty coverage and may result in costly water damage.
- Proper installation is the responsibility of the installer. Product failure or property damage due to improper installation is not covered under the warranty.
- See the instruction manual provided with the icemaker for icemaker installation. Failure to install the icemaker within these guidelines may adversely affect safety, performance, component life, and warranty coverage.
- Clean, sanitize and maintain the icemaker per the instructions provided in the icemaker's instruction manual. If the instruction manual is not available, consult with your local distributor or call Perlick Technical Service Support at (800) 558-5592 in the USA.
- **THE ICEMAKER MUST BE GROUNDED:** The icemaker is equipped with a 3-prong grounding plug to reduce the risk of potential shock hazards. It must be plugged into a properly grounded, independent 3-prong wall outlet. If the outlet is a 2-prong outlet, it is your personal responsibility to have a qualified electrician replace it with a properly grounded, independent 3-prong wall outlet. Do not remove the ground plug from the power cord and do not use an adapter plug.
- The icemaker and this kit must be installed in accordance with applicable national, state, and local codes and regulations.
- Protect the floor when moving the icemaker to prevent damage to the floor.
- This drain pump is approved for use only with the models listed.



Drain Pump Kit for Undercounter Clear Ice Makers

For use with H50IMS, H50IMW and H50IMS-AD Clear Ice Makers

INSTALLATION INSTRUCTIONS

This drain pump is designed to remove drain water from an undercounter icemaker in areas without direct drainage access. The drain pump reservoir collects drain water and pumps it through a 1/2" ID high pressure clear pvc hose (discharge hose). The maximum discharge hose length is 20 feet. The maximum lift height is 8 feet. There is a factory installed check valve on the drain pump.

NOTICE! Do not install any additional check valves.

1. Move the control switch to the "OFF" position and unplug the unit from the electrical outlet.
2. Remove the rear access panel and rear cover (see Fig. 1). Disconnect the drain house and remove the rear drain bracket and drain fitting.
3. If the sheet metal tabs are present on your unit, remove them (see Fig. 2).
4. Remove the original drain hose and install the new drain hose (5/8" ID x 6.5") provided in this kit (see Fig. 3). On -AD, cut the new drain hose to a length of 5". Secure the new drain hose with one of the large clamps provided in this kit. **CAUTION! Do not over-tighten the clamp.**

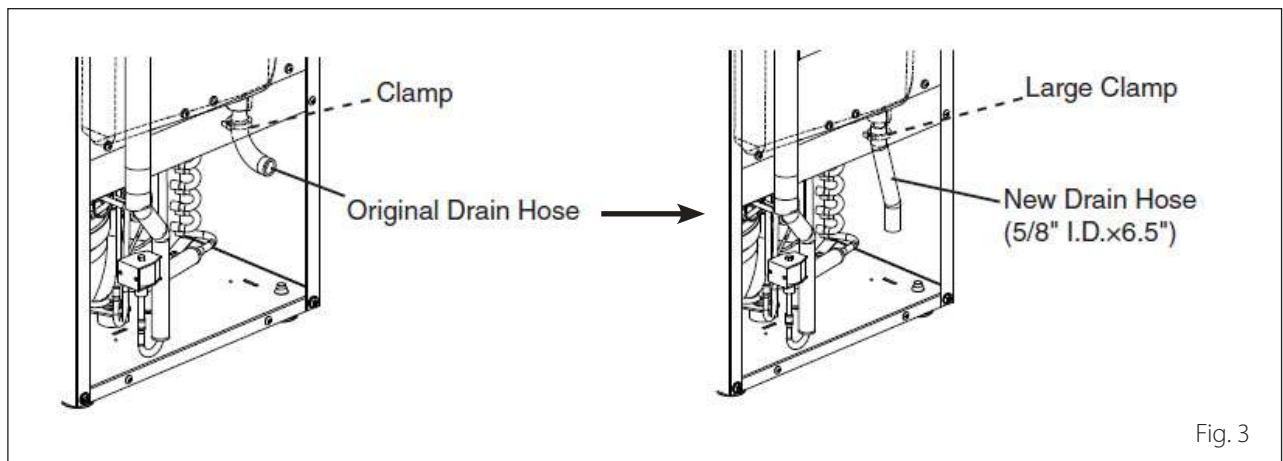
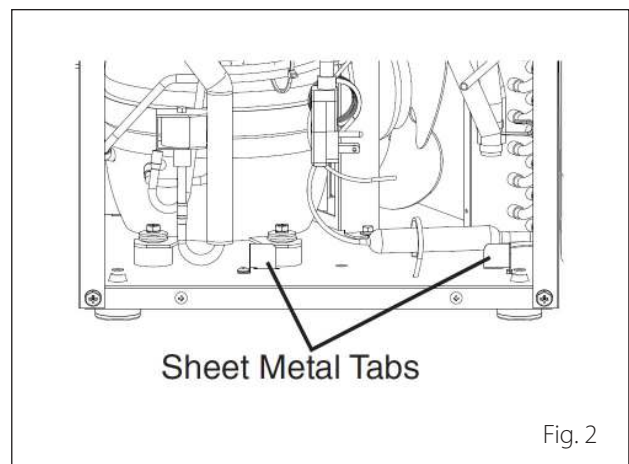
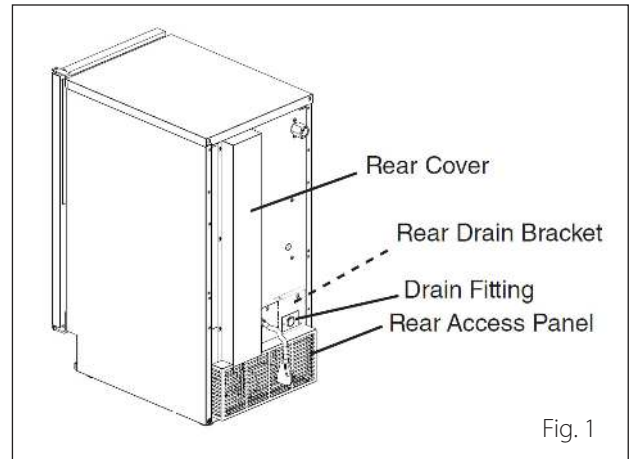

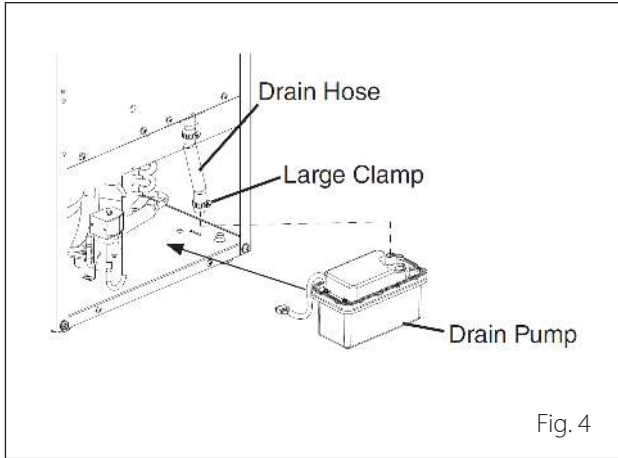

5. Carefully place the drain pump into the open space provided at the rear of the icemaker. The drain pump will overhang the base slightly. (See Fig. 4). If necessary, carefully bend or move the icemaker's copper tubing so that it does not make contact with the drain pump, hoses, or other parts of the icemaker.. **CAUTION! Drain pump MUST be level.**
6. Connect the drain hose/drain elbow to the drain pump as illustrated (see Fig. 4). Secure the drain hose/drain elbow with the remaining large clamp provided in this kit. **CAUTION! Do not over-tighten the clamp.**
7. Remove the jumper plug from the icemaker's drain pump connector. (See Fig. 5). The jumper plug is not needed when a drain pump is installed.
8. Connect the drain pump plug to the icemaker's drain pump connector.

Continued on page 4

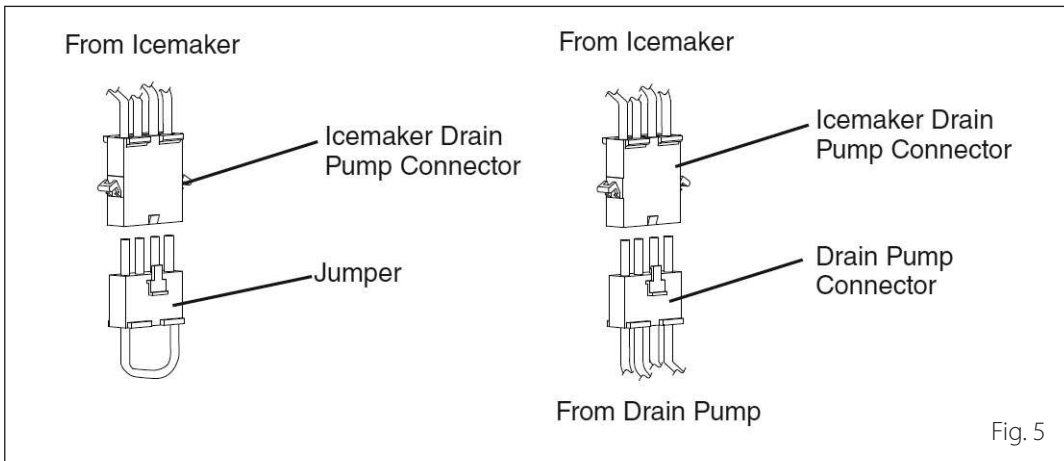



Drain Pump Kit for Undercounter Clear Ice Makers

For use with H50IMS, H50IMW and H50IMS-AD Clear Ice Makers

- Cut the 3/8" ID vent hose to a length of 19.5"
 - On non -AD units, route the vent hose (3/8" I.D. x 19.5") through the drain fitting area (vent hose access area) in the rear access panel (see Fig. 6).
 - On -AD units, route the vent hose through the 23 mm diameter vent hose access hole in the rear access panel. (See Fig. 7). If the rear access panel does not have a vent hose access hole, drill a 23 mm or 3/4" diameter hole into the rear access panel.
 - Secure the vent hose to the drain pump with the small tubing clamp provided. Use pliers to tighten the clamp. **CAUTION! Do not over-tighten the clamp.**
 - Route one end of the discharge hose (1/2" ID x 10') through the drain fitting area in the rear access panel. Connect the discharge hose to the drain pump (See Fig. 8).
 - Reinstall the rear cover and rear access panel in their correct positions. (See Fig. 10).
- ⚠ WARNING**
Make sure that there are no wires pinched between the rear access panel, rear cover, or icemaker.
- Secure the vent hose to the icemaker using the two hose clips and two 4x8 truss head screws provided. (See Fig. 9). Screw holes are provided. **CAUTION! The vent hose must be attached and secured to the icemaker or water damage may occur. Make certain there are no kinks in the vent hose. The drain pump will not operate correctly with a partially blocked vent hose.**

Continued on page 5

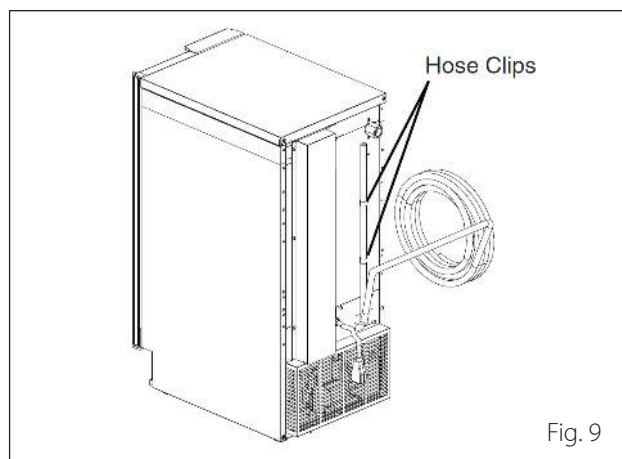
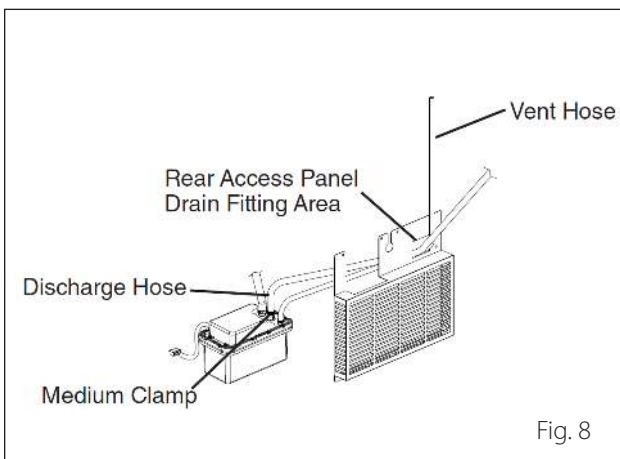
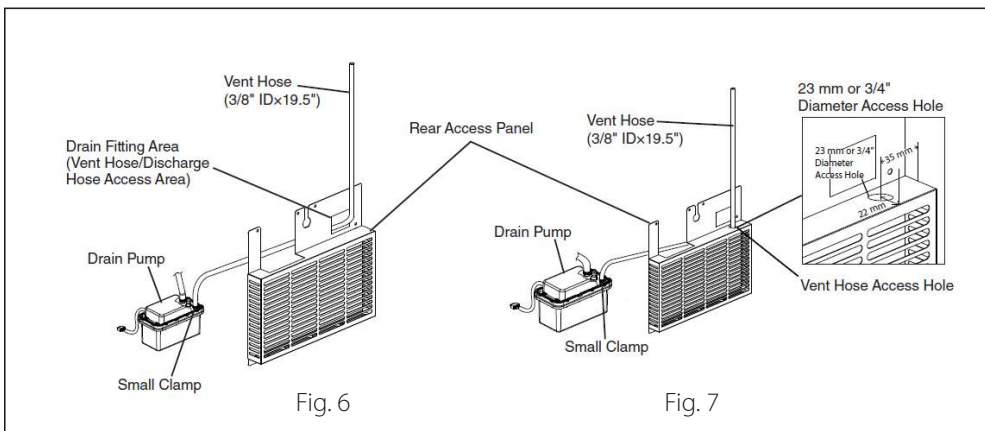



16. Connect the discharge hose to a suitable drain. Do not connect the discharge hose directly to a drain pipe or a floor drain. An air gap of a minimum of 2" (50.8 mm) should be between the end of the discharge hose and the floor drain or drain piping. **NOTICE! Be sure there is a sufficient extra tubing for the unit to be pulled out for service.** Do not allow traps or kinks in the hose that will restrict water flow. The maximum discharge hose length is 20 feet. The maximum discharge hose lift height is 8 feet. Cut excess hose as needed.
17. Make sure the icemaker control switch is in the 'OFF' position. Plug the icemaker into the electrical outlet. **WARNING! To reduce the risk of electrical shock, do not touch the control switch or plug with damp hands.**

PRIMING INSTRUCTIONS

18. Slowly pour 16 to 24 oz. (500 to 750 ml) of water over the storage bin drain hole in the storage bin.
19. Once the drain pump energizes, disconnect the icemaker's power cord from the electrical outlet, then reconnect to the electrical outlet. **WARNING! To reduce the risk of electric shock, do not touch the plug with damp hands.**
20. Slowly pour another 16 to 24 oz. (500 to 750 ml) of water over the storage bin drain hole in the storage bin/ If not already energized, the drain pump should energize.
21. Confirm that water discharged through the discharge hose. The drain pump should then de-energize. If not, repeat steps 18 through 20 until water is discharged through the discharge hose and the drain pump de-energizes. The drain pump is primed when the drain pump de-energizes. **NOTICE! Failure to prime the drain pump in accordance with these instructions will adversely affect performance, component life, and warranty coverage and may result in costly water damage.**
22. Make sure there are no water leaks.
23. To test the operation of the drain pump internal safety switch, move the control switch to the 'ICE' position. Pour another 16 to 24 oz/ (500 to 750 ml) of water into the icemaker's ice storage bin, then completely restrict the discharge hose while the drain pump is operating. Pour more water into the icemaker's storage bin until the icemaker turns off. The drain pump will continue to operate. Check for leaks. remove the discharge hose restriction and allows the water to be pumped out normally. The power to the icemaker will be restored when the water in the drain pump returns to a normal level.

24. Place the icemaker in the final installation location. **WARNING! Protect the floor when moving the icemaker to prevent damage to the floor. Make sure you do not damage or pinch the water supply line, discharge tubing, drain connections, or power cord. Be sure there is sufficient extra tubing for the unit to be pulled out for service.**

FINAL CHECKLIST

- Is the drain pump level?
- Have all electrical and water connections been made per this installation manual and the instruction manual provided with the icemaker? **WARNING! To reduce the risk of electrical shock, do not touch the control switch, drain pump plug, or power cord plug with damp hands. Make sure you do not damage or pinch the inlet water supply line, drain pump discharge tubing, drain pump connections or power cord.**
- Are all the water connections free of leaks?
- Has the drain pump been properly primed and tested?
- Has sufficient extra tubing been left for the unit to be pulled out for service?
- Are the water supply tube, vent hose, and discharge hose free of kinks?
- Has the end user been given these instructions and instructed on the importance of the recommended periodic maintenance?
- Has the end user been given the name and telephone number of an authorized service agent?

Continued on page 6



Drain Pump Kit for Undercounter Clear Ice Makers

For use with H50IMS, H50IMW and H50IMS-AD Clear Ice Makers

MAINTENANCE

Clean, sanitize, and maintain the icemaker per the instructions provided in the icemaker's instruction manual. If the instruction manual is not available, consult with your local distributor, visit www.perlick.com, or call Perlick Technical Service at (800) 558-5592 in the USA.

TROUBLESHOOTING

Icemaker does not run:

- Make sure there is power at the electrical outlet
- Make sure the icemaker's control switch is in the 'ICE' position.
- Make sure the icemaker's ice storage bin is not full.
- Make sure the drain pump is properly connected to the icemaker.
- The icemaker will not run if the drain pump is filled to capacity, but the drain pump will continue to operate. When the water level lowers, the icemaker will restart.

Drain pump does not run:

- Make sure there is power at the electrical outlet.
- Make sure the hole at the top of the drain pump inlet fitting is clear and that there is nothing blocking water flow to the drain pump. Clean as needed.
- Make sure the vent hose is open and free of kinks and sharp bends.
- Make sure there is enough water to activate the drain pump. It takes at least 1 pint (500 ml) of water to activate the drain pump.

The drain pump runs but no water is pumped out:

- Make sure the discharge hose is free of foreign material and free of traps and kinks.
- Make sure the discharge hose has not exceeded the maximum horizontal length of 20 feet or the maximum lift height of 8 feet.
- Make sure the pump is primed. See steps 17 through 20.

NOTE: IF THE DRAIN PUMP FAILS, WATER WILL REMAIN IN THE DRAIN PUMP AND ICEMAKER IF INSTALLED PROPERLY.

WARRANTY

This optional Perlick drain pump carries a one year parts and labor warranty. The warranty begins on the installation date of the drain pump. For warranty validation, be sure to properly register your icemaker.

INSTALLER NOTES

Leave this instruction manual along with the icemaker instruction manual and warranty information with the end user for future reference.

Model Number of Icemaker: _____

Serial Number of Icemaker: _____

Drain Pump Installation Date: _____

CONTACT INFORMATION

Perlick Corporation
8300 West Good Hope Rd.
Milwaukee, WI 53223

Telephone: (800) 558-5592
www.perlick.com

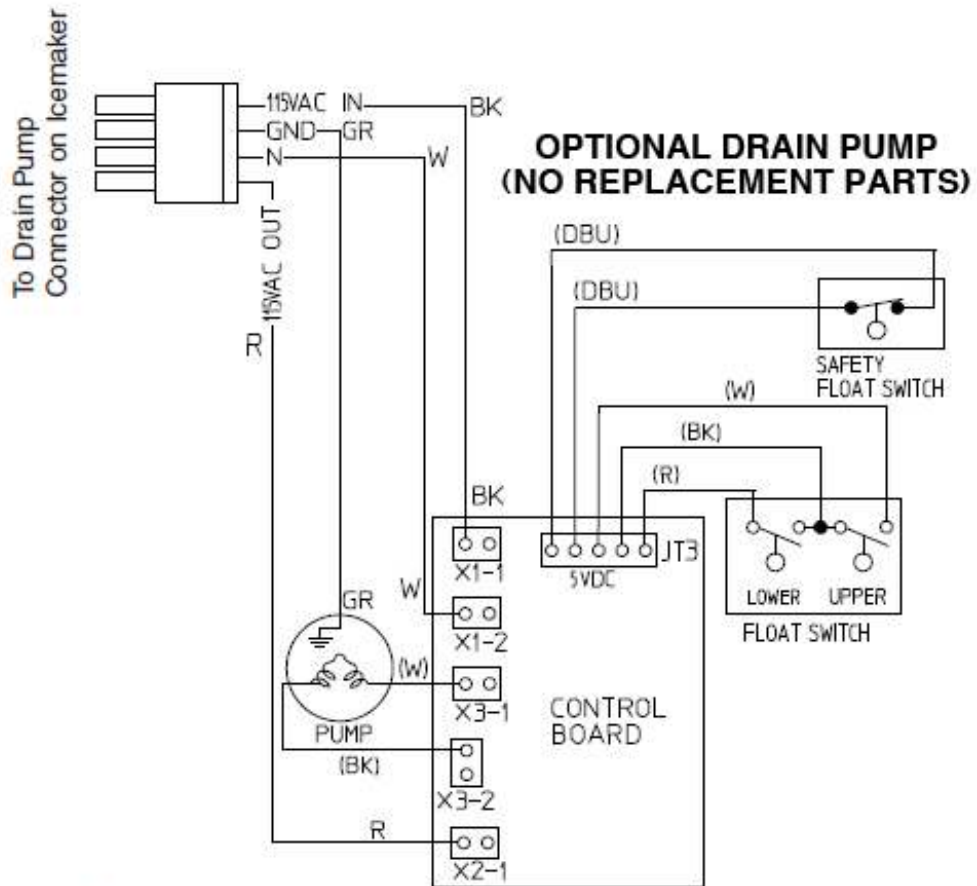

Wire Color Code
 BK-BLACK
 DBU-DARK BLUE
 GR-GREEN
 R-RED
 W-WHITE

Voltage Code
 GND-GROUND
 N-NEUTRAL



Luxury YOU DESIRE



INNOVATION YOU CAN'T LIVE WITHOUT

8300 West Good Hope Road • Milwaukee, WI 53223 •

Toll Free 800.558.5592 • Fax 414.353.7069 • www.bringperlickhome.com