



# IN-LINE HEATER

# INSTALLATION, OPERATION AND MAINTENANCE

---

## MODELS:

**6ILS**  
**5.5 kW**  
**240V SINGLE PHASE**

### BEFORE YOU BEGIN

CHECK ALL ELECTRICAL CONNECTIONS TO ALL COMPONENTS WITHIN THE HEATER FOR TIGHTNESS. CONNECTIONS CAN BECOME LOOSE DURING SHIPMENT AND HANDLING.

### CAUTION

THE ELECTRICAL INSTALLATION MUST BE IN ACCORDANCE WITH ARTICLE 680 OF THE NATIONAL ELECTRICAL CODE.

### WARNING

Only qualified personnel, as defined by National Electric Code Article 100, should install and maintain this equipment. Unauthorized alteration or improper maintenance of this unit may release the manufacturer from any warranty claims. The installation must be in accordance with the instructions in this manual and applicable local plumbing and electrical codes.

## 1.0 DESCRIPTION

Coates Spa Heaters are intended for use on spas or hot tubs having a forced water circulation system.

The water flow through the heater should be at least 15 GPM but should not exceed 70 GPM. Higher flow may damage the heater. An external bypass should be installed to limit the flow to within this range.

## 2.0 INSTALLATION

### WARNING

Only qualified personnel, as defined by National Electric Code Article 100, should install and maintain this equipment. Unauthorized alteration or improper maintenance of this unit may release the manufacturer from any warranty claims. The installation must be in accordance with the instructions in this manual and applicable local plumbing and electrical codes.

CHECK ELECTRICAL CONNECTIONS TO ALL COMPONENTS within the heater for tightness. These can become loose during shipment and handling.

## 2.1 PHYSICAL PLACEMENT

### CAUTION

THE ELECTRICAL INSTALLATION MUST BE IN ACCORDANCE WITH ARTICLE 680 OF THE NATIONAL ELECTRICAL CODE (NEC).

The Coates Spa Heater is suitable for indoor installation. See Figure 1 for piping connections and Figure 2 for electrical connections. **Leave minimum clearance of 4 inches on the top for element removal and service access.**

## 2.2 ELECTRICAL INSTALLATION

The electrical supply power must be single phase, 2 wire, 240 VAC. The supply must be protected by a ground fault circuit interrupter (GFCI) in accordance with NEC Article 680. An electrical disconnect with over-current protection must be provided. An insulated ground conductor must be provided. See Figure 2 for electrical connections. A lug has been provided for attachment of the BONDING wire per the NEC Article 680-22, (a)(4). This lug is located next to the conduit entrance.

\*\* NOTICE \*\*

NO PRESSURE RELIEF VALVE IS SHIPPED WITH THIS HEATER AND NONE IS REQUIRED PER UL STD 1261. DO NOT INSTALL SHUT OFF VALVE BETWEEN THE HEATER AND POOL OR SPA. A CHECK VALVE IS ACCEPTABLE AND IN ACCORDANCE TO UL STD 1261 REVISED JULY 1983.

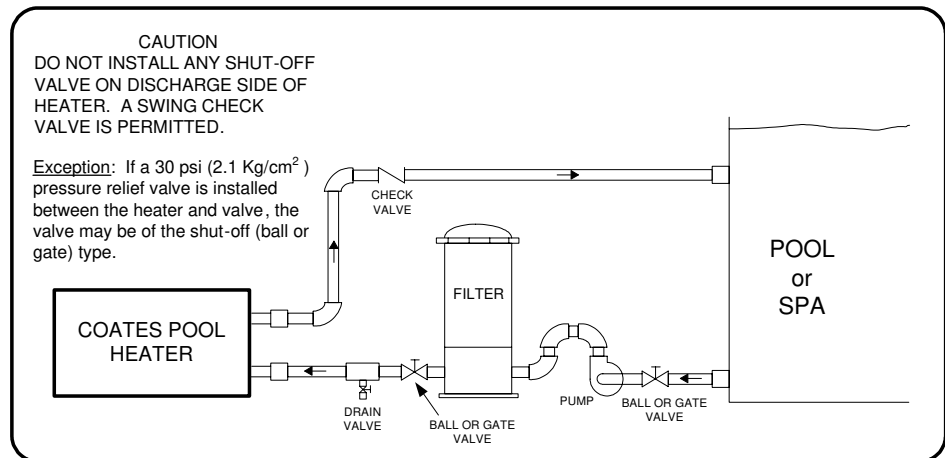

FIGURE 1 – PIPING DIAGRAM

240VAC SINGLE PHASE  
HEATER SUPPLY WIRES  
#10AWG CU 90°C Min.

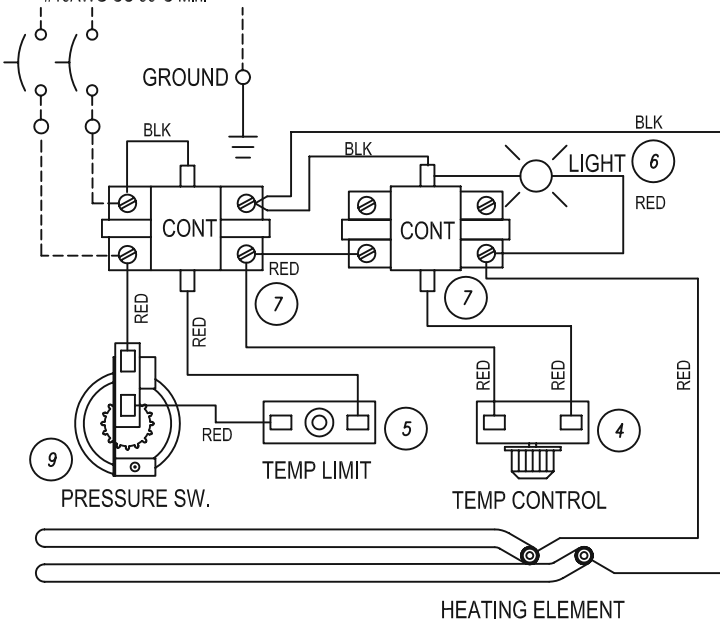

Figure 2 Wiring diagram

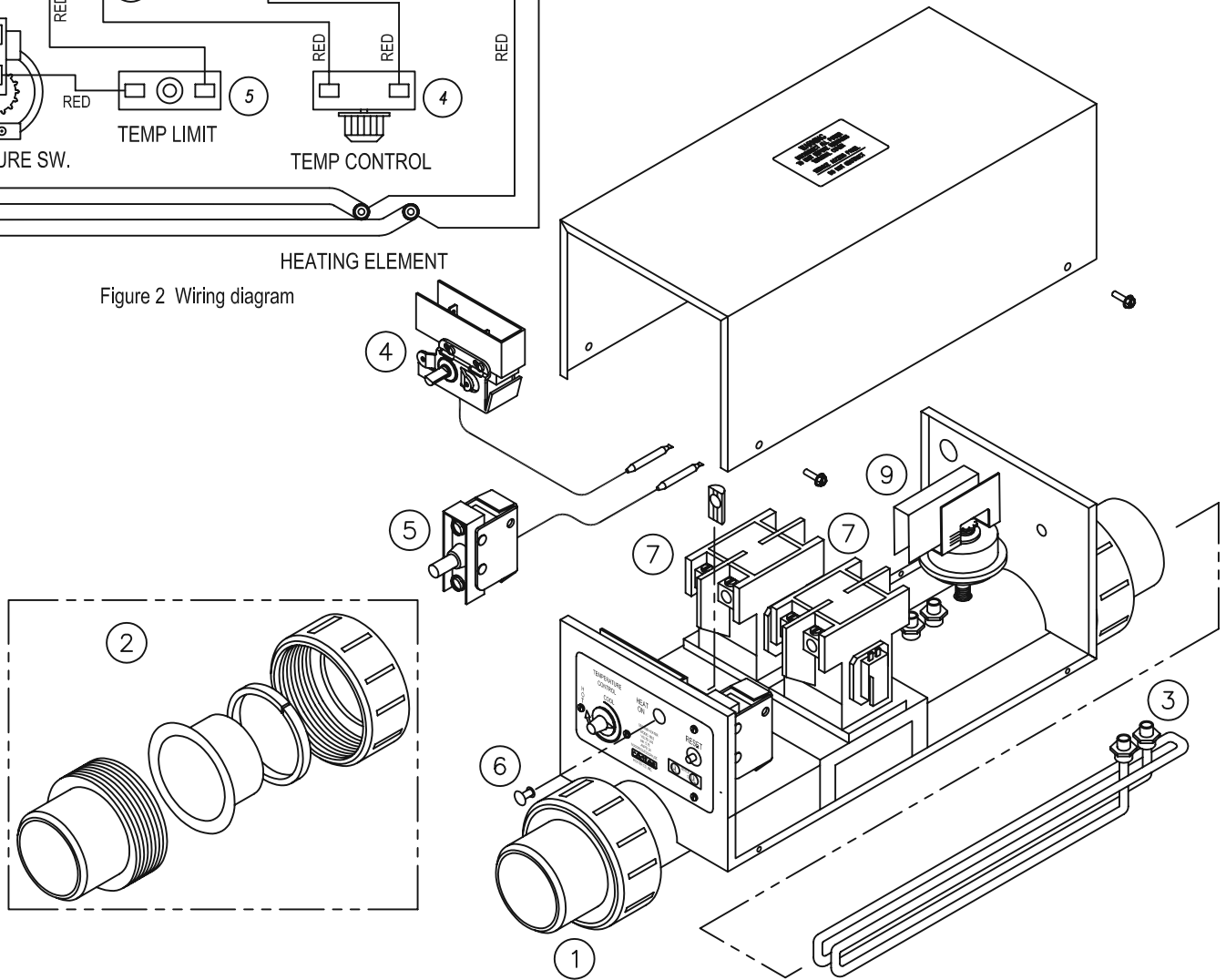

TABLE 1

ITEM	PART NUMBER	DESCRIPTION	QTY
1	62002615	SS VESSEL WITH HEATING ELEMENT AND UNIONS	1
2	32705020	PVC UNION ASSEMBLY W/TAIL, NUT, RETAINER AND GASKET	2
3	20005155	HEATING ELEMENT, 5.5kW 240V AC	1
4	22002001	TEMPERATURE CONTROL	1
5	22003820	HIGH TEMPERATURE LIMIT, MANUAL RESET	1
6	29034620	PILOT LIGHT FOR ELEMENT	1
7	21000650	CONTACTOR, 2-POLE, 240V AC COIL	2
8	--	N/A	
9	22007210	PRESSURE SWITCH, 1-5 PSI	1

WHEN ORDERING PARTS FROM YOUR DEALER, PROVIDE THE MODEL NUMBER AND SERIAL NUMBER OF YOUR HEATER

### 3.0 HEATER CONTROLS

The heater has a temperature controller adjustable from 70°F to 104°F, one manual reset type high temperature limit switch set at 118°F and a pressure switch to prevent operation of heater without water flow.

#### 3.1 CAUTIONS AND WARNINGS

1. Be sure to check all cautions and warnings in this manual and as displayed on the heater labels before operating or performing any maintenance on this heater.
2. Do not remove the heater cover while electrical power is applied to the heater. Power must be interrupted at the heater supply circuit breaker or disconnect switch.
3. The MIN setting on the temperature control dial is an OFF position. The heater will not operate at this setting regardless of water temperature.

#### 3.2 STARTING THE HEATER

##### - CAUTION -

Do not operate heater without water.

1. Ensure that heater case is properly grounded, and bonded.
2. Fill the system with water and start the circulating pump.
3. Turn on electrical power at the heater supply circuit breaker.
4. Set the temperature control to desired water temperature and adjust accordingly after the temperature has stabilized. DO NOT EXCEED 104°F.

#### 3.3 STOPPING THE HEATER

1. Turn off electrical power at the heater supply circuit breaker before stopping the circulating pump.

#### 3.4 PRESSURE SWITCH ADJUSTMENT

The pressure switch, as factory set, should provide proper operation for many installations. If the heater is installed above or below the level of the spa or if a two speed pump is used the pressure switch may need to be adjusted for proper operation.

##### **WARNING**

All checks and adjustments to the pressure switch must be made with heater power supply off.

To verify the correct operation of the switch, perform the following;

1. If pump has two speeds, set at low speed.
2. Disconnect the line voltage leads to the pressure switch and connect an ohm meter or other continuity tester across the switch terminals.
3. Switch the pump on and off.

The pressure switch should close with the pump on and open with the pump off. If it does not, perform one of the following;

1. Switch closed with pump off – turn the black thumbscrew clockwise (higher pressure) until the switch opens.
2. Switch open with pump on – turn the black thumbscrew counter-clockwise (lower pressure) until the switch closes.
3. “Chattering” switch action with pump on – turn the black thumbscrew counter-clockwise (lower pressure) until switch stays closed.

#### 4.0 MAINTENANCE

1. Keep the heater clean.
2. If high temperature causes the limit thermostat to cut off the electrical power, turn off power at disconnect switch and determine the cause before resetting the switch. A water temperature drop is required to allow resetting of the manual reset high temperature limit.
3. If leaks develop in the heater or connecting piping, shut down the heater and repair defective connections.
4. If heating elements are removed for replacement, use only Coates elements.

#### 5.0 OPERATION SEQUENCE

1. Power supplied to heater (Circuit Breaker).
2. Pressure switch closes (with sufficient flow from pump).
3. Rotate temperature dial until it is greater than water temperature.
4. Element light illuminates and the element heats the water.

**WARNING:**  
**Only qualified personnel should attempt maintenance on this equipment. (NEC Article 100)**

## HEATER TROUBLE SHOOTING GUIDE

- CAUTION -

This heater incorporates 240 volt electrical circuits.  
 Do not open the case unless unit is disconnected from electrical power.  
 Use only manufacturer's parts, or UL listing and warranty may be void.

PROBLEM	INDICATORS	POSSIBLE CAUSES	ACTION
No Heat	"HEAT" light <b>OFF</b>	No Power to heater	Check Circuit Breaker "ON".
		Insufficient Flow/Pressure	Check that pump is running and filter is clean.
		Pressure Switch out of adjustment	Consult this manual, <b>Section 3.4</b> , for adjustment instructions.
		Pressure Switch inoperative	Use Ohm meter to check continuity across switch while pump is running. Replace Pressure Switch if Open.
	"HEAT" light <b>ON</b>	Heating Element inoperative	Replace Element as required.

Insufficient Heat	"HEAT" light <b>ON</b>	Heater too small for Spa	Check heater sizing requirement of Spa.
-------------------	------------------------	--------------------------	---

High Limit RESET Trips	"HEAT" light <b>OFF</b>	Temperature control inoperative, water overheats in Spa.	Replace Temperature Control.
		Pressure Switch not turning off heater when pump/flow stops	Consult this <b>Manual Section 3.4</b> for adjustment instructions. Replace as required.
		Heater subjected to high ambient temperature (i.e. Direct sunlight)	Cool Equipment room or shade heater from sun.
		High Limit switch inoperative	Replace High Limit Switch

Water Temp Greater than setpoint	"HEAT" light <b>ON</b>	Thermostat out of calibration/ inoperative	Replace thermostat.
	"HEAT" light <b>OFF</b>	External heat source (i.e. Solar Heating, heat from the pump, etc.)	Turn off power to heater and verify problem continues.

Elements can be checked with an Ohm meter only when power is disconnected from heater and all wires have been removed from the element terminals. Each element should read approximately 10.5 Ohms.

Ambient temperatures above 120°F will cause the high temperature limit to trip prematurely.

### PROTECTING YOUR COATES HEATER WITH PROPER WATER CHEMISTRY

Proper water balance is important to extending the life of your Coates Heater. While pH control is critical, the control of alkalinity and calcium hardness will protect against scaling and also help to prevent corrosion.

		ACID							ALKALINE								
HEATER CAN BE DAMAGED	CORROSIVE WATER							IDEAL RANGE	ALKALINE WATER							HEATER CAN BE DAMAGED	
	0	1	2	3	4	5	6		7	8	9	10	11	12	13		14
								7.2-7.8									

The correct level of sanitizer, pH, total alkalinity and calcium hardness will vary, depending on the type of pool (plaster, fiberglass or vinyl) and the chemical content of the fill water. Water that is out of balance can damage your pool heater and void the warranty. This heater is not for use in salt water pools.

# LIMITED WARRANTY

The company extends this limited warranty to the original purchaser of a Coates Electric Spa Heater.

Coates warrants the electrical components\* and wiring (excluding enclosure, enclosure parts, knobs and accessories) in this new Spa Heater to be free from defects in materials and workmanship for one (1) year from the provable date of purchase, or eighteen (18) months from date of factory shipment, whichever occurs first. Coates further warrants the stainless steel water containment vessel to be free from defects in materials and workmanship for two (2) years from the provable date of purchase or thirty (30) months from the factory shipment, whichever occurs first. Enclosure, enclosure parts, knobs and accessories have no warranty whatsoever.

\*Exception: Factory installed heating elements are warranted for ninety (90) days from the date of heater installation, or one (1) year from date of factory shipment, whichever occurs first.

COATES will repair or replace at its option, defective component parts as explained above, during the warranty period provided such parts are returned to the factory, freight prepaid. Factory authorization **MUST BE OBTAINED** under this warranty before returning such defective parts.

## Limited Warranty Does Not Cover

1. New products purchased outside the United States of America and Canada.
2. Uncrating, unpacking, set-up, installation and / or startup of this unit.
3. Adjustments to controls normally operated by consumer, purchaser or installer.
4. This limited warranty does not extend to any defect, malfunction or failure caused by, or resulting from improper service, maintenance or repair, abuse, neglect, accident, **corrosion caused by improper water chemistry or by equipment that use salt to create a sanitizer**, lack of water, or any other cause beyond the control of Coates Heater Company, Inc. or to any product where the nameplate shall have been removed, altered, replaced, defaced or rendered illegible.
5. This limited warranty is void if the Heater is used in a salt water system or under any extreme or unusual corrosive condition for which stainless steel metals would not be recommended.
6. This limited warranty does not extend to the repair or replacement of defective components except at COATES or a service facility authorized by COATES

IMPLIED WARRANTIES, WHEN APPLICABLE, SHALL COMMENCE UPON THE SAME DATE AS THE EXPRESS WARRANTY PROVIDED ABOVE, AND SHALL, EXCEPT FOR WARRANTIES OF TITLE, EXTEND ONLY FOR THE DURATION OF THE EXPRESS WARRANTY. SOME STATES DO NOT ALLOW LIMITATIONS ON HOW LONG AN IMPLIED WARRANTY LASTS, SO THE ABOVE LIMITATION MAY NOT APPLY TO YOU. THE ONLY REMEDY PROVIDED TO YOU UNDER AN APPLICABLE IMPLIED WARRANTY AND THE EXPRESS WARRANTY SHALL BE THE REMEDY PROVIDED UNDER THE EXPRESS WARRANTY, SUBJECT TO THE TERMS AND CONDITIONS CONTAINED THEREIN.

COATES SHALL NOT BE LIABLE FOR INCIDENTAL AND CONSEQUENTIAL LOSSES AND DAMAGES, UNDER THE EXPRESS WARRANTY, ANY APPLICABLE IMPLIED WARRANTY, OR CLAIMS FOR NEGLIGENCE, EXCEPT TO THE EXTENT THAT THIS LIMITATION IS FOUND TO BE UNENFORCEABLE UNDER APPLICABLE STATE LAW.

SOME STATES DO NOT ALLOW THE EXCLUSION OF LIMITATION OF INCIDENTAL OR CONSEQUENTIAL DAMAGES, SO THE ABOVE LIMITATION OR EXCLUSION MAY NOT APPLY TO YOU.

THIS WARRANTY GIVES YOU SPECIFIC LEGAL RIGHTS, AND YOU MAY ALSO HAVE OTHER RIGHTS WHICH VARY FROM STATE TO STATE.



**HEATER COMPANY, INC.**

P.O. Box 1750  
Kent, WA 98035