

Raypak
A Rheem® Company

Commercial Pool Heaters

Rugged, efficient heaters for large pools

Clubs. Universities.
Municipalities. Watersport
Centers. Large residential pools.

23 model sizes — 511,500 to
4,000,000 BTUH inputs.

Indoor and outdoor styles.

82% thermal efficiency.

Natural or propane gas.

Fuel-saving electronic ignition.

Precision water temperature
control to $\pm 1^\circ\text{F}$.

Low operating and maintenance
cost. Easy service.



MODEL P-1336 INDOOR

These heaters are design certified and tested under the requirements of ANSI Z21.56 / CSA 4.7 American National Standard / CSA Standard for Gas-Fired Pool Heaters. A Raypak commercial pool heater is unrivaled for its heating efficiency, operating economy, low-cost installation and all-around dependability. Each unit is fired up and tested prior to shipment to ensure optimal onsite performance. Check these standard features and see why Raypak is the best!

Electronic Pilot Ignition...Saves fuel, no standing pilot.

100% Copper And Bronze Waterways...Bronze headers and 1" cupro nickel finned tubes prevent corrosion and rust which can stain the pool and destroy the heater.

Tough, Durable Polytuf Powdercoat Finish...Long-lasting all-weather protection in durable Forest Green color.

Unitherm Governor...Standard on Models P-514 to P-1223, a patented 3-way valve built in the header, automatically maintains the water in the heater at the precise temperature that prevents condensation and scale.

By-Pass Pump...Standard on Models P-1287 thru P-4001 and Optional on models P-926 to P-1223, a properly designed bypass pump is used to control the temperature of the water entering the heater to avoid condensation and scaling.

Cold War Run...Optional on Models P-926 to P-4001, utilizes a variable-speed pump to inject just the right amount of water from the main loop into the boiler to maintain optimum inlet temperature and protect against condensation.

Interlocking Combustion Chamber...Cuts heat loss for best efficiency. Keeps jacket cool.

Dual Gas Valves...For safety.

Stainless Steel Burners...Can't clog or corrode.

Slide-out Burner Tray...For easy inspection and maintenance.

Protecto Vent Top (outdoor only)...Wind, rain and debris proof.



www.raypak.com

2151 Eastman Avenue | Oxnard, CA 93030 | 805-278-5300

Models P-514 to P-824:

Equipped with Unitherm Governor

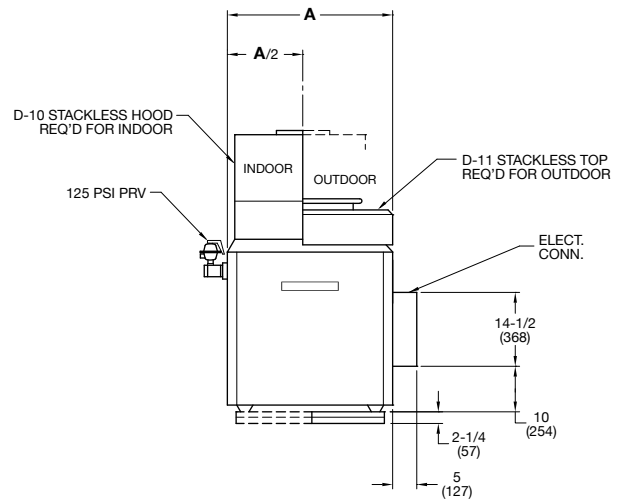
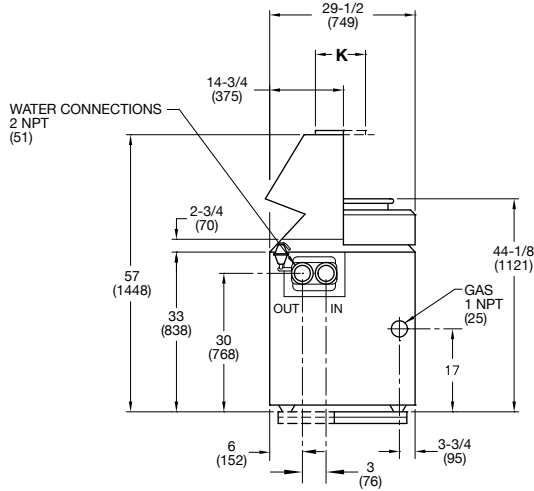

Combustible floor shield (optional).

MODEL	INPUT MBTUH (kw)		OUTPUT MBTUH (kw)		DIMENSIONS in. (mm)		SHIP WEIGHT lbs (kg)
	NAT	PRO	NAT	PRO	WIDTH (A)	FLUE DIA. (K)	
P-514	511.5 (150)	481 (141)	419.4 (123)	394.4 (116)	32-3/4 (832)	10 (254)	405 (184)
P-624	627 (184)	589 (173)	514.2 (151)	483 (142)	37-1/2 (953)	12 (305)	425 (193)
P-724	726 (213)	682 (200)	595.3 (174)	559.2 (164)	41-5/8 (1057)	12 (305)	460 (209)
P-824	825 (242)	775 (227)	676.5 (198)	635.5 (186)	45-3/4 (1162)	14 (356)	495 (224)

Models P-926 to P-1178:

Equipped with Unitherm Governor (standard)

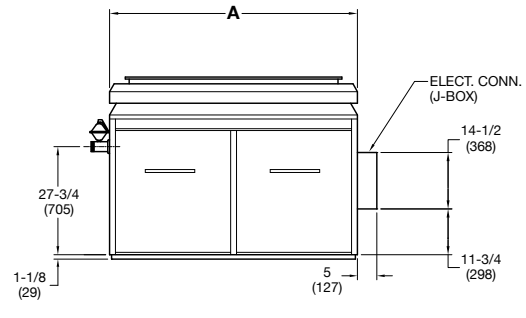
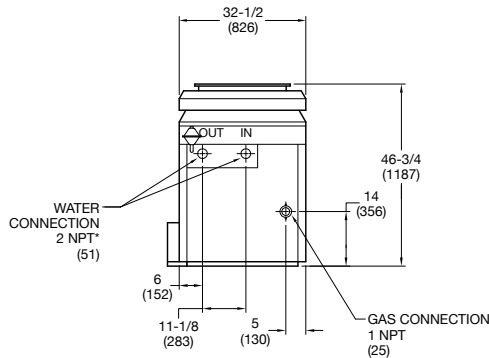

MODEL	INPUT MBTUH (kw)		OUTPUT MBTUH (kw)		DIMENSIONS in. (mm)		SHIP WEIGHT lbs (kg)
	NAT	PRO	NAT	PRO	WIDTH (A)	FLUE DIA.	
P-926	926 (271)	885 (259)	759.3 (223)	725.7 (213)	52-3/8 (1330)	14 (356)	600 (272)
P-1083	1083 (317)	1035 (303)	888.1 (260)	848.7 (249)	59-1/4 (1505)	16 (406)	745 (338)
P-1178	1178 (345)	1125 (330)	966 (283)	922.5 (270)	63-5/8 (1616)	16 (406)	760 (345)

* 2 NPT (51 mm) with UG Option. 2-1/2 NPT (64 mm) with H-Bypass.

Equipped with H-bypass (optional)

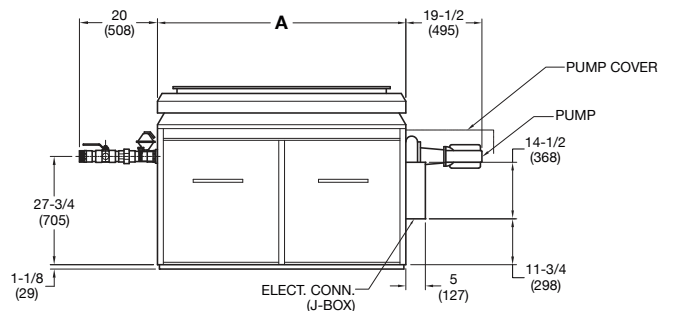

Models P-926 to P-1178:

With Cold Water Run (optional)

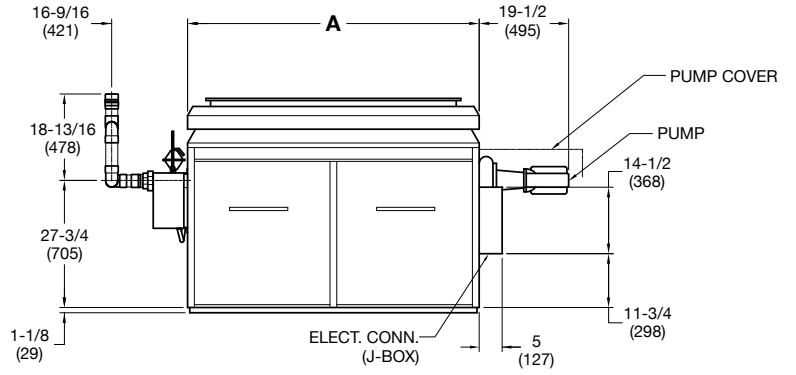
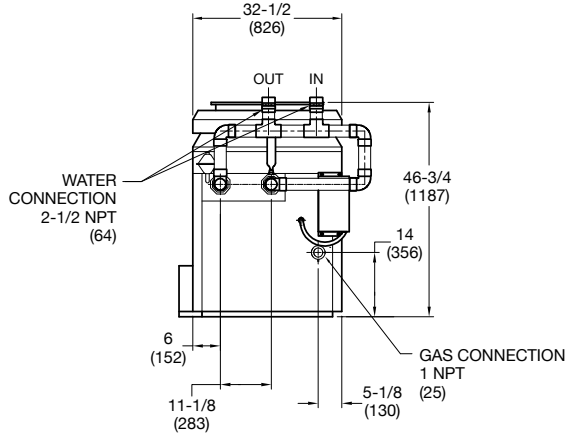

Models P-962 to P-1223:

Equipped with Unitherm Governor (standard)

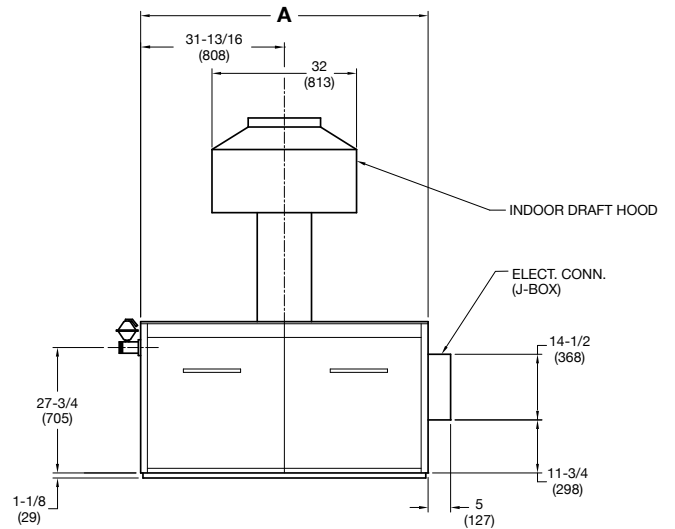
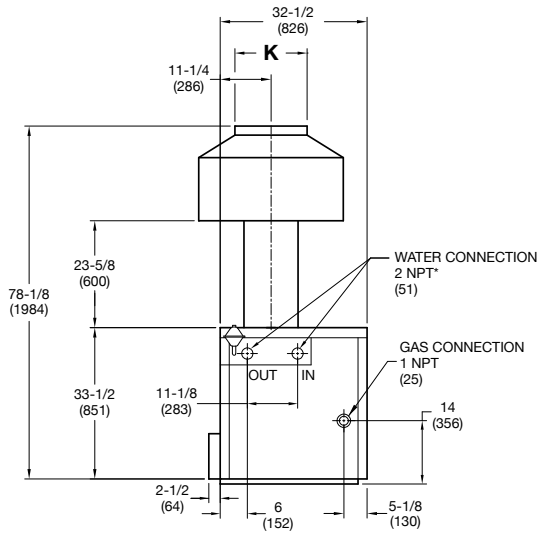

Equipped with H-bypass (optional)

MODEL	INPUT MBTUH (kw)		OUTPUT MBTUH (kw)		DIMENSIONS in. (mm)		SHIP WEIGHT lbs (kg)
	NAT	PRO	NAT	PRO	WIDTH (A)	FLUE DIA. (K)	
P-962	961.7 (282)	885 (259)	788.6 (231)	725.7 (213)	52-3/8 (1330)	14 (356)	620 (281)
P-1125	1124.7 (330)	1035 (303)	922.3 (270)	848.7 (249)	59-1/4 (1505)	16 (406)	690 (313)
P-1223	1222.5 (358)	1125 (330)	1002.5 (294)	922.5 (270)	63-5/8 (1616)	16 (406)	890 (404)

* 2 NPT (51 mm) with UG Option. 2-1/2 NPT (64 mm) with H-Bypass.

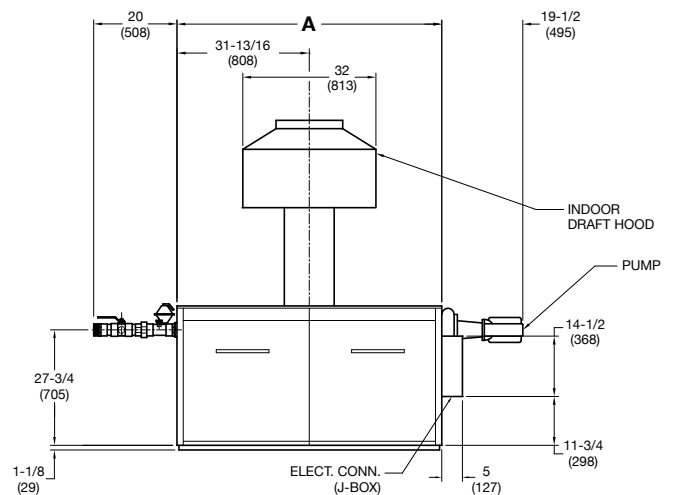

Models P-962 to P-1223:

With Cold Water Run (optional)

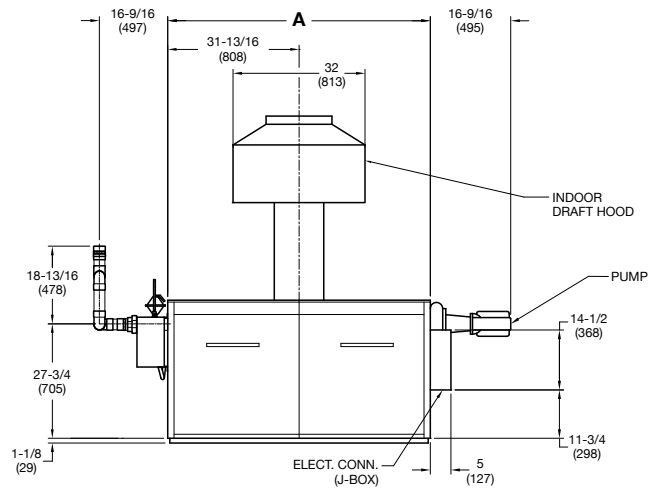
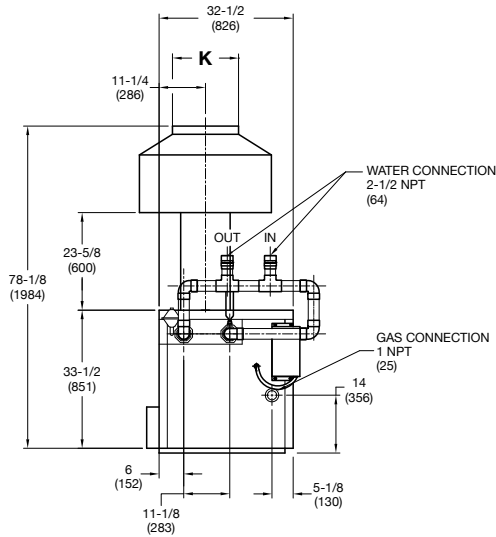

Models P-1287:

Equipped with H-Bypass and Rear-Mounted Pump (standard)

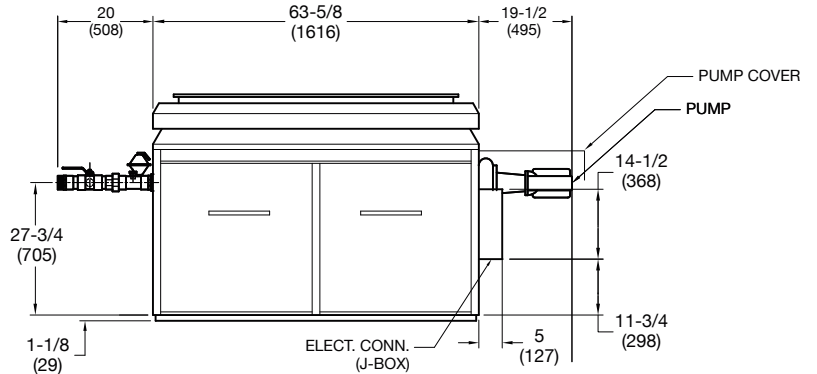
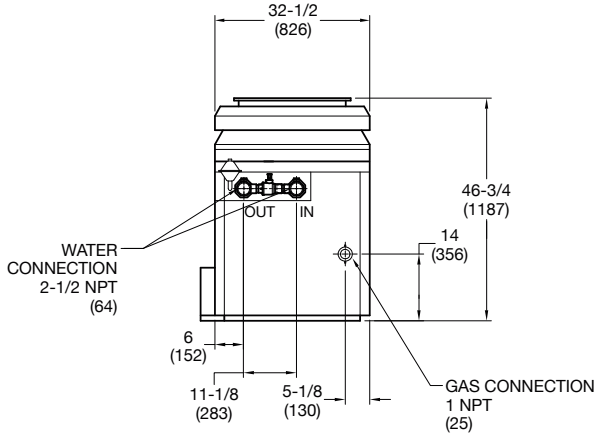

With Cold Water Run (optional)

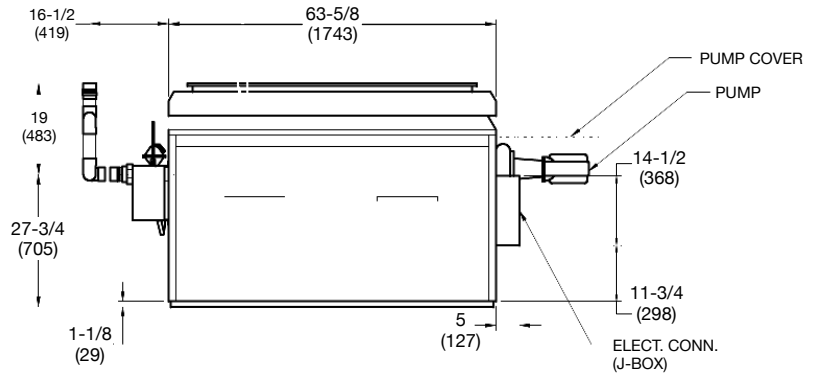
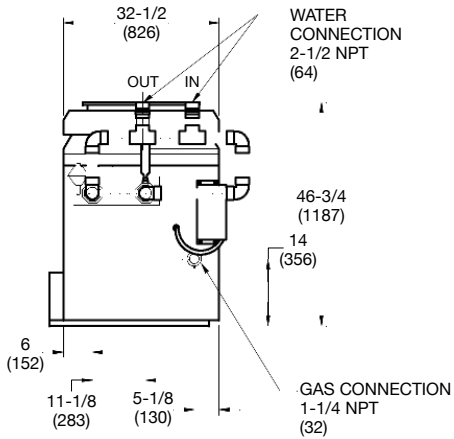

MODEL	INPUT MBTUH (kw)		OUTPUT MBTUH (kw)		FLUE DIA. in. (mm)	SHIP WEIGHT lbs (kg)
	NAT	PRO	NAT	PRO		
P-1287	1287 (377)	1230 (360)	1055.3 (309)	1008.6 (296)	18 (457)	1076 (488)

Models P-1336:

Equipped with H-Bypass and Rear-Mounted Pump (standard)

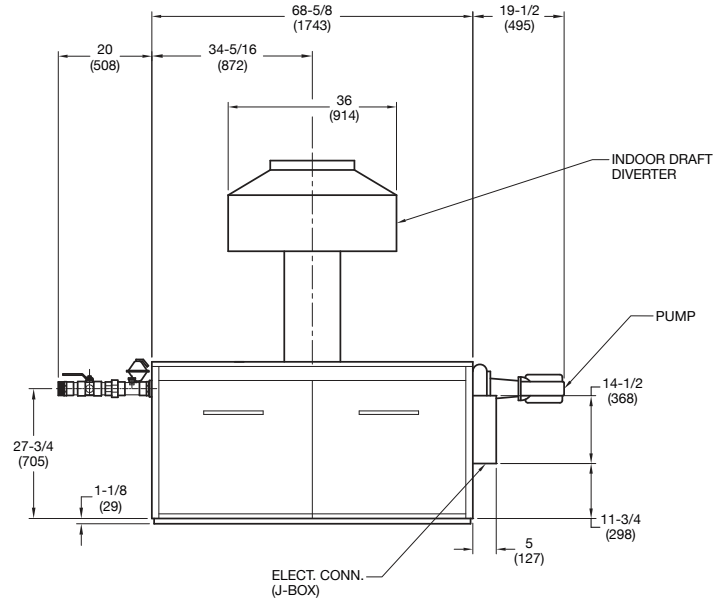
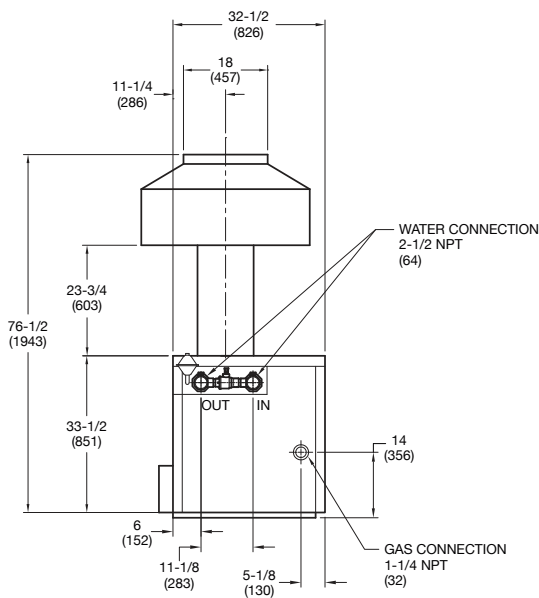

Combustible floor shield (optional).

With Cold Water Run (optional)

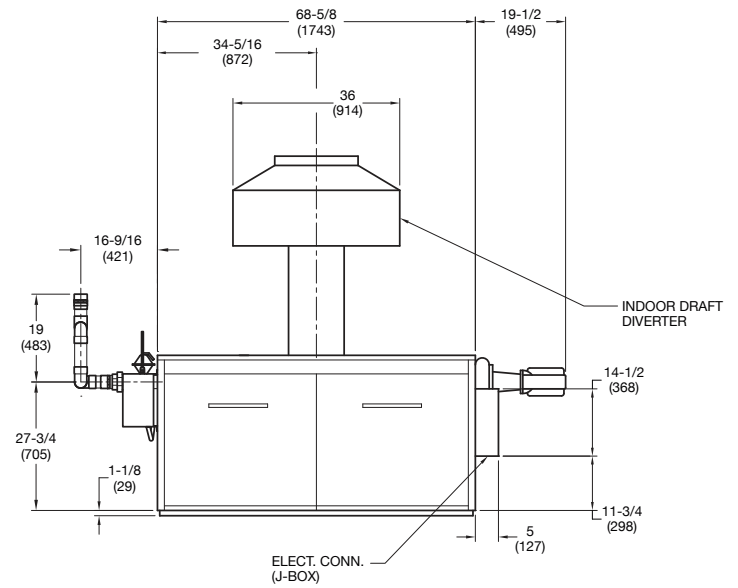
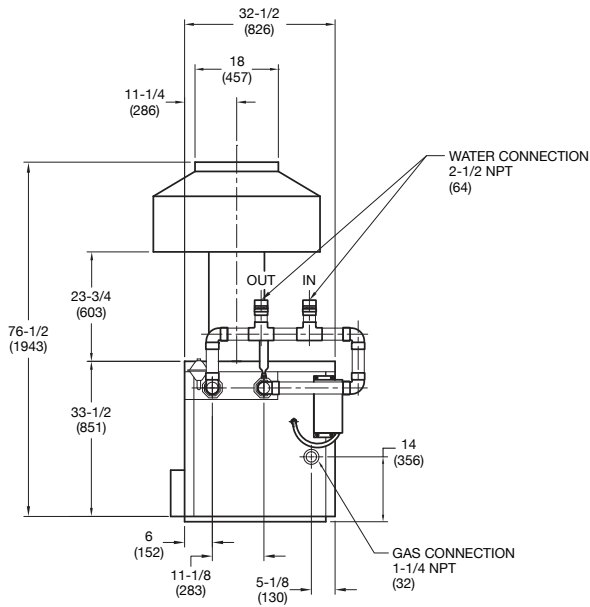

MODEL	INPUT MBTUH (kw)		OUTPUT MBTUH (kw)		FLUE DIA. in. (mm)	SHIP WEIGHT lbs (kg)
	NAT	PRO	NAT	PRO		
P-1336	1336.6 (317)	1230 (360)	1083 (317)	1008.6 (296)	18 (457)	925 (420)

Models P-1414 to P-1758:

Equipped with H-Bypass (standard)

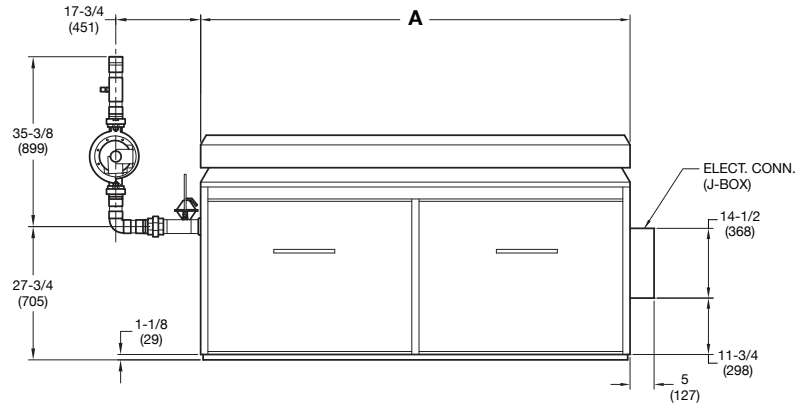
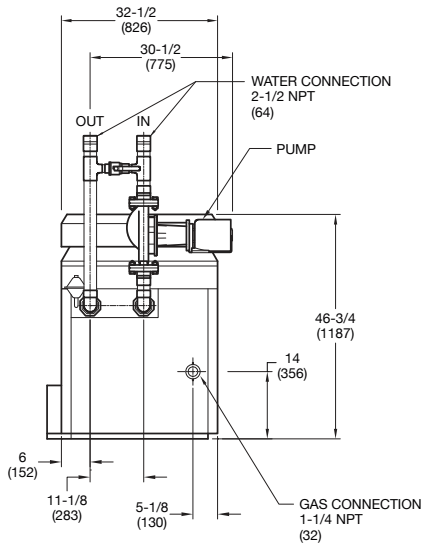

MODEL	INPUT MBTUH (kw)		OUTPUT MBTUH (kw)		DIMENSIONS in. (mm)		SHIP WEIGHT lbs (kg)
	NAT	PRO	NAT	PRO	WIDTH (A)	FLUE DIA.	
P-1414	1413 (414)	1350 (396)	1159 (340)	1107 (324)	74-7/8 (1902)	18 (457)	1105 (501)
P-1571	1570 (460)	1500 (440)	1287.4 (377)	1230 (360)	81-1/8 (2061)	18 (457)	1235 (560)
P-1758	1758 (515)	1680 (492)	1441.6 (422)	1377.6 (404)	89-3/8 (2270)	20 (508)	1300 (590)

Equipped with Cold Water Run (optional)

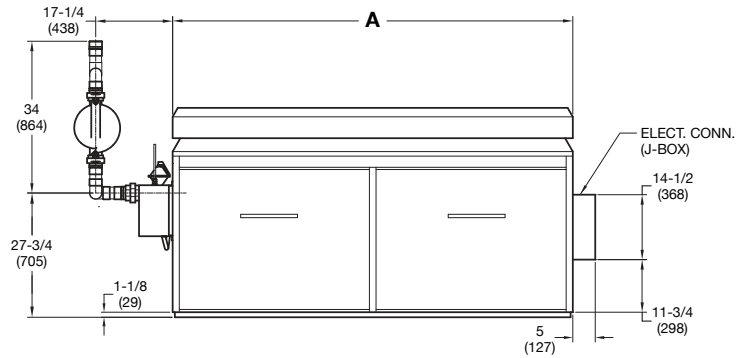
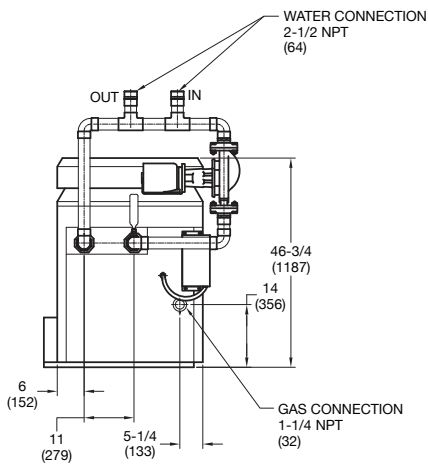
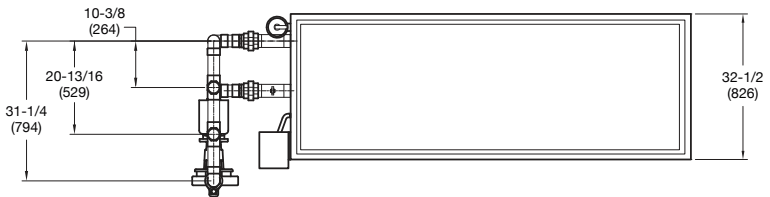

Models P-1468 to P-1826:

Equipped with H-Bypass (standard)

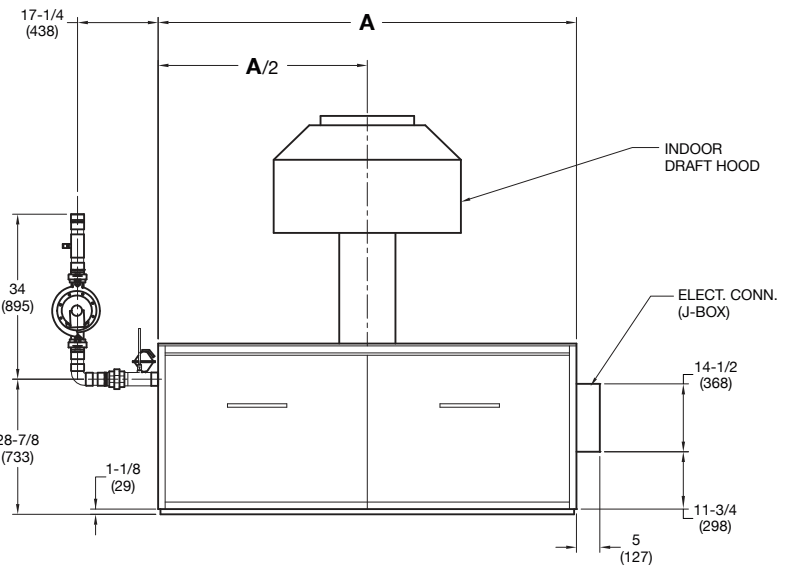
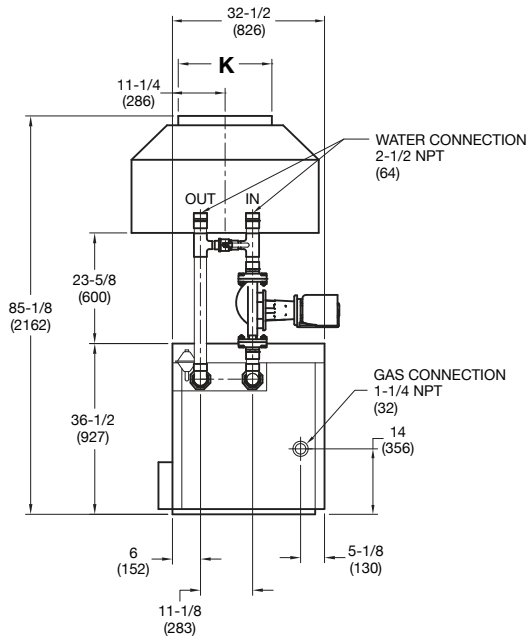

Combustible floor shield (optional).

MODEL	INPUT MBTUH (kw)		OUTPUT MBTUH (kw)		DIMENSIONS in. (mm)		SHIP WEIGHT lbs (kg)
	NAT	PRO	NAT	PRO	WIDTH (A)	FLUE DIA. (K)	
P-1468	1467 (430)	1350 (396)	1203 (353)	1107 (324)	74-7/8 (1902)	18 (457)	976 (443)
P-1631	1630 (478)	1500 (440)	1336.6 (392)	1230 (360)	81-1/8 (2061)	18 (457)	1040 (472)
P-1826	1825.6 (535)	1680 (492)	1497 (439)	1377.6 (404)	89-3/8 (2270)	20 (508)	1088 (493)

Equipped with Cold Water Run (optional)

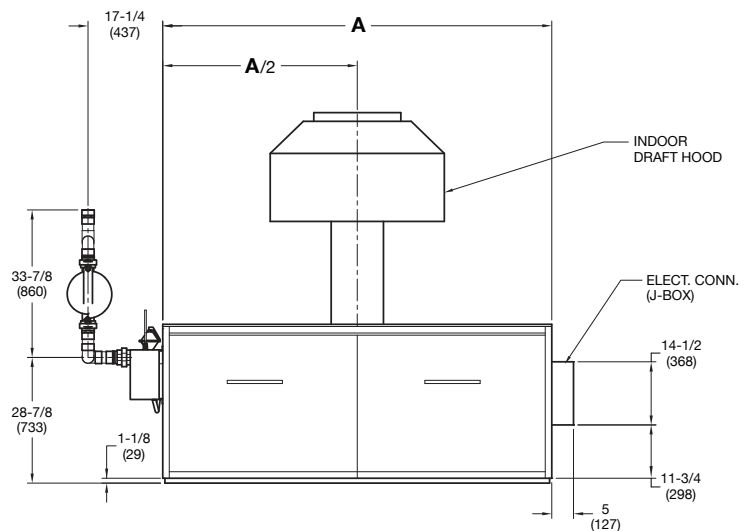
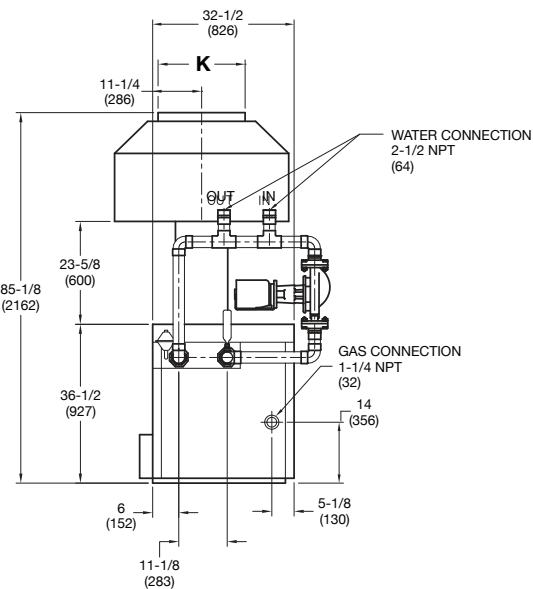
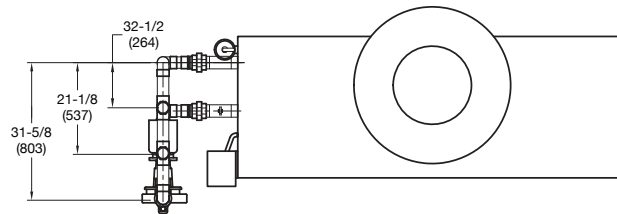

Combustible floor shield (optional).

Models P-2100 to P-4001:

Equipped with H-Bypass (standard)

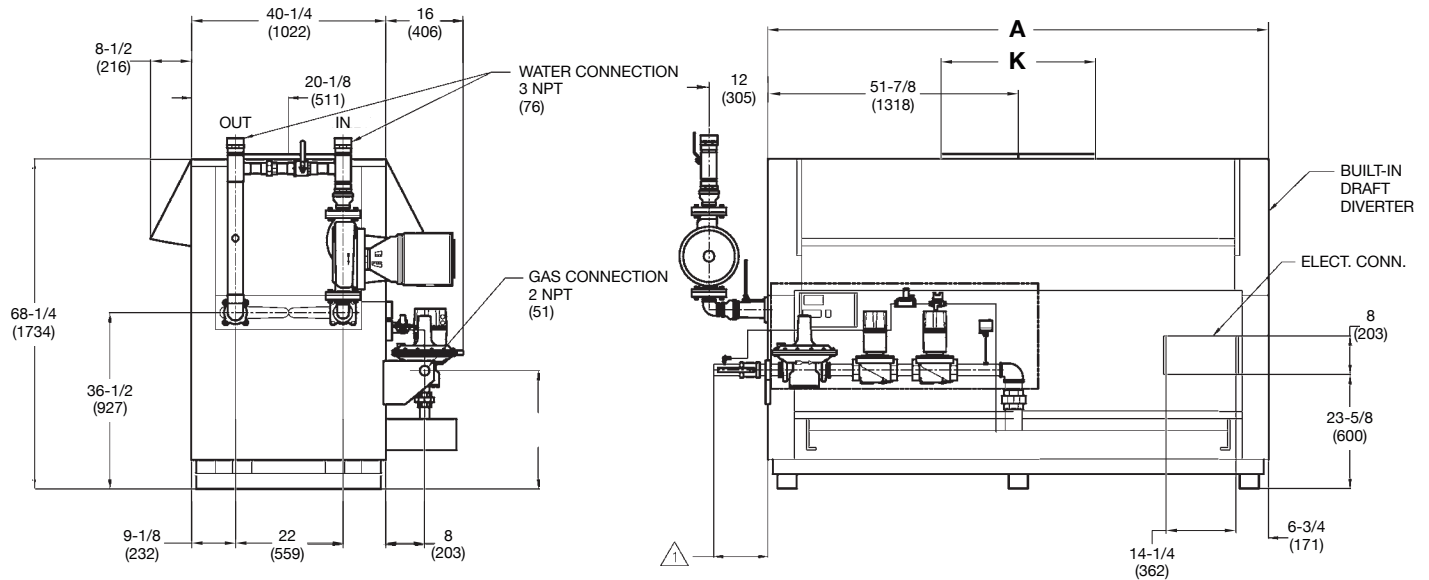

Combustible floor shield (optional).

MODEL	INPUT MBTUH (kw)		OUTPUT MBTUH (kw)		DIMENSIONS in. (mm)		SHIP WEIGHT lbs (kg)
	NAT	PRO	NAT	PRO	WIDTH (A)	FLUE DIA. (K)	
P-2100	2100 (615)	2100 (615)	1722 (505)	1722 (505)	61 (1549)	24 (610)	1580 (717)
P-2500	2499 (732)	2499 (732)	2049.2 (601)	2049.2 (601)	70 (1778)	26 (660)	1780 (807)
P-3001	3000 (879)	3000 (879)	2460 (721)	2460 (721)	81-1/4 (2064)	28 (711)	2000 (907)
P-3500	3500 (1026)	3500 (1026)	2870 (841)	2870 (841)	92-1/2 (2350)	30 (762)	2180 (989)
P-4001	4000 (1172)	4000 (1172)	3280 (961)	3280 (961)	103-3/4 (2635)	32 (813)	2500 (1134)

Note 1: 1-1/2" or 2" Contingent on code requirements.

Equipped with Cold Water Run (optional)

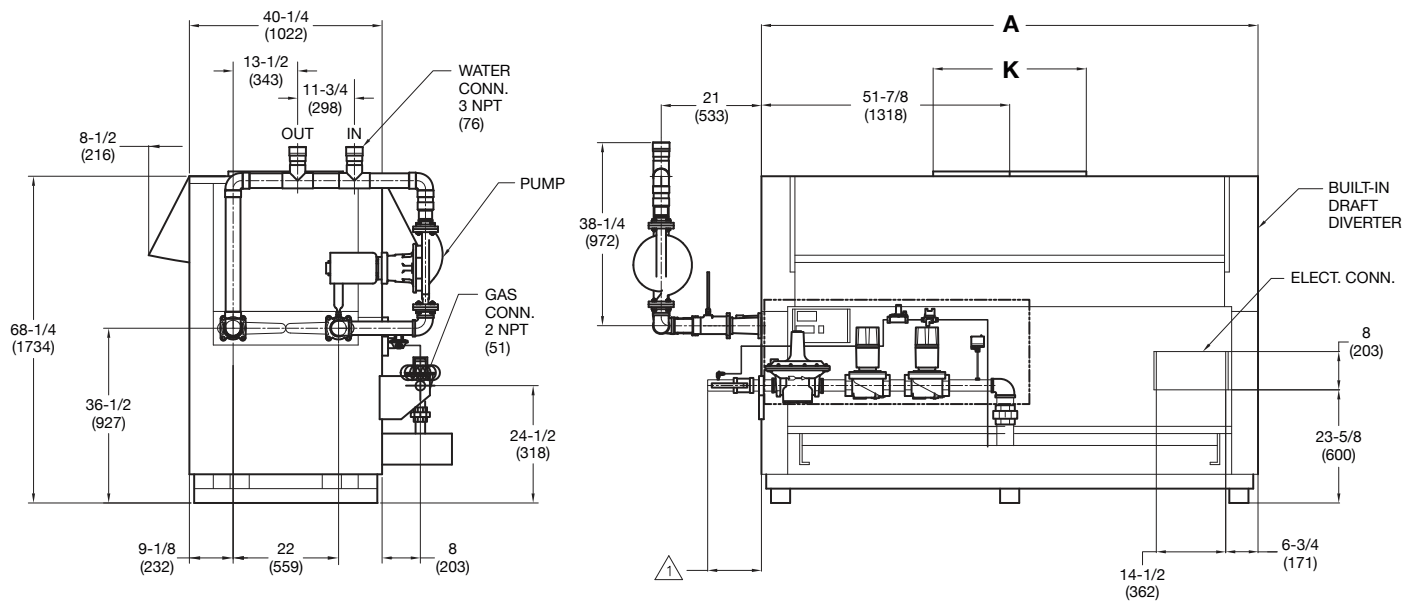

Combustible floor shield (optional).