

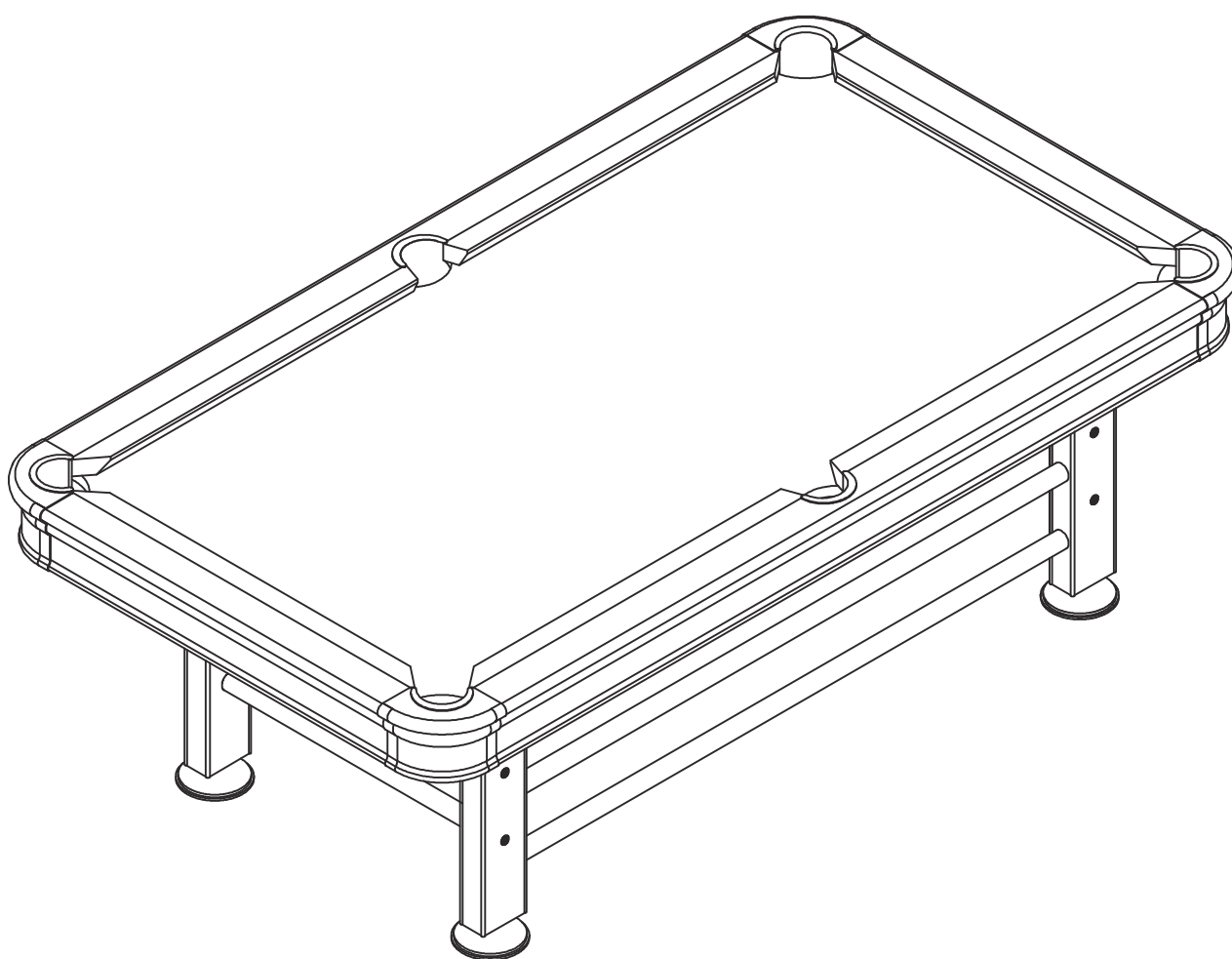







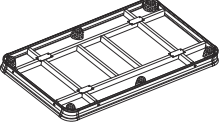
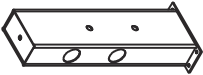
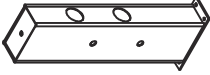
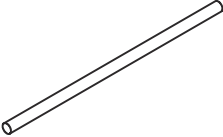
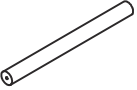

CHAMBERLAIN GAME TABLES

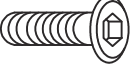
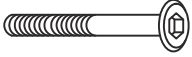
ASSEMBLY INSTRUCTIONS FOR

"MALIBU NIGHTS" 7' OUTDOOR POOL TABLE

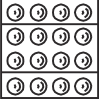
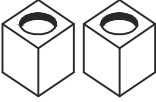
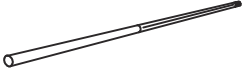

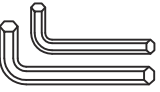
Part List

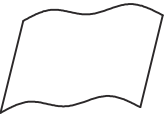
<p>P1</p>  <p>Cabinet 1pc</p>	<p>P2</p>  <p>LEG.A 2pcs</p>	<p>P3</p>  <p>LEG.B 2pcs</p>	<p>P4</p>  <p>LONG CROSS BAR 2pcs</p>	<p>P5</p>  <p>SHORT CROSS BAR 2pcs</p>
<p>P6</p>  <p>LEG LEVELER 4 pcs</p>	<p>H1</p>  <p>5/16x5/8" BOLT 16pcs</p>	<p>H2</p>  <p>1/4x4" BOLT 8pcs</p>	<p>H3</p>  <p>5/16" WASHER 16pcs</p>	<p>H4</p>  <p>1/4" WASHER 8pcs</p>
<p>H5</p>  <p>ALUMINUM TUBE 8pcs</p>	<p>A1</p>  <p>BILLIARD BALL 1set</p>	<p>A2</p>  <p>CHALK 2pcs</p>	<p>A3</p>  <p>CUE STICK 2pcs</p>	<p>A4</p>  <p>TRIANGLE 1pc</p>
<p>A5</p>  <p>TOOL 2pcs</p>	<p>A6</p>  <p>BRUSH 1pc</p>	<p>A7</p>  <p>TABLE COVER 1pc</p>		

DO NOT SIT ON TABLE !

ASSEMBLY INSTRUCTIONS

WARNING: TWO ADULTS NEEDED TO ASSEMBLE SOCCER TABLE

Step 1

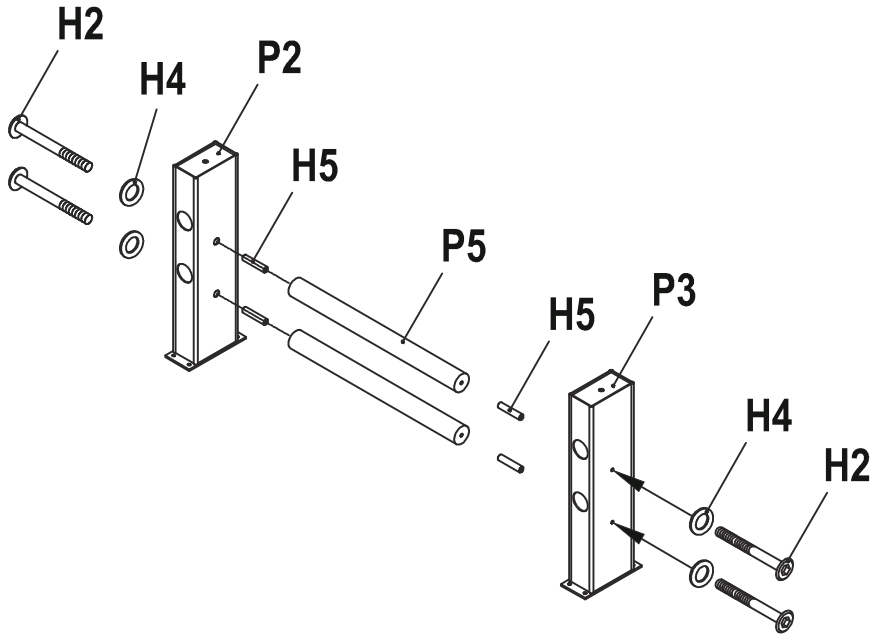

Step 2

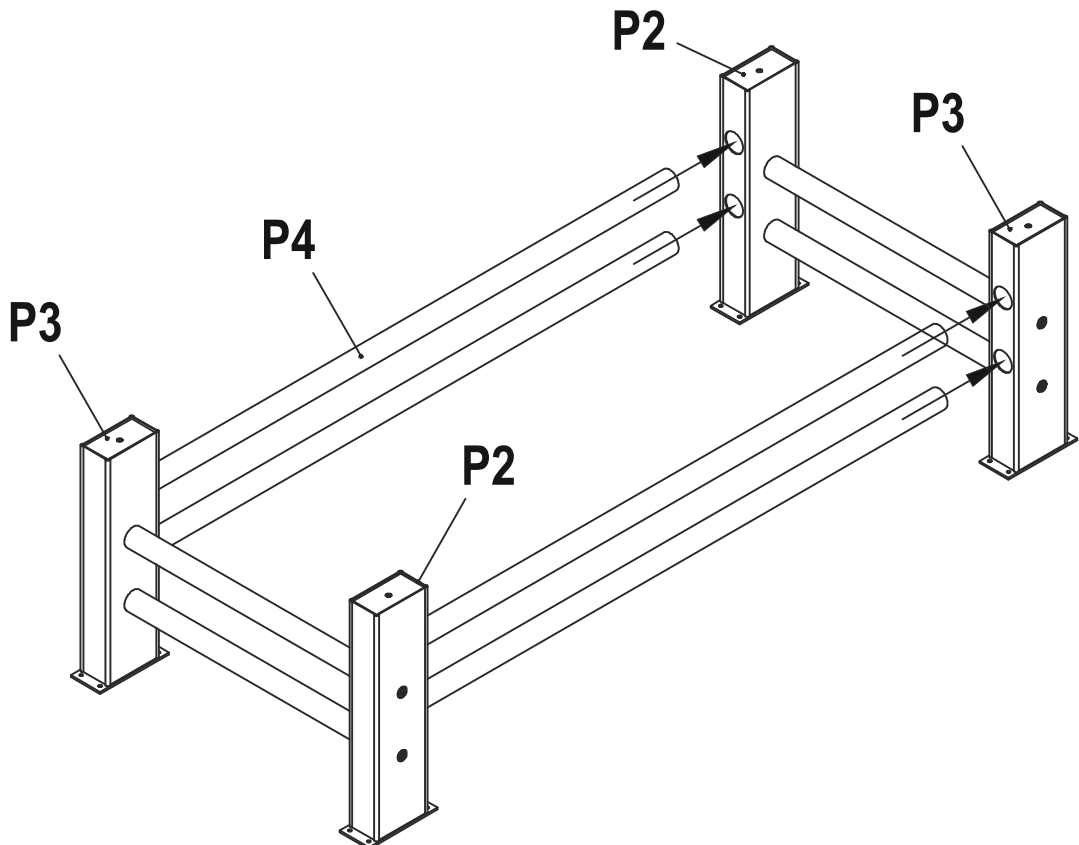

Step 3

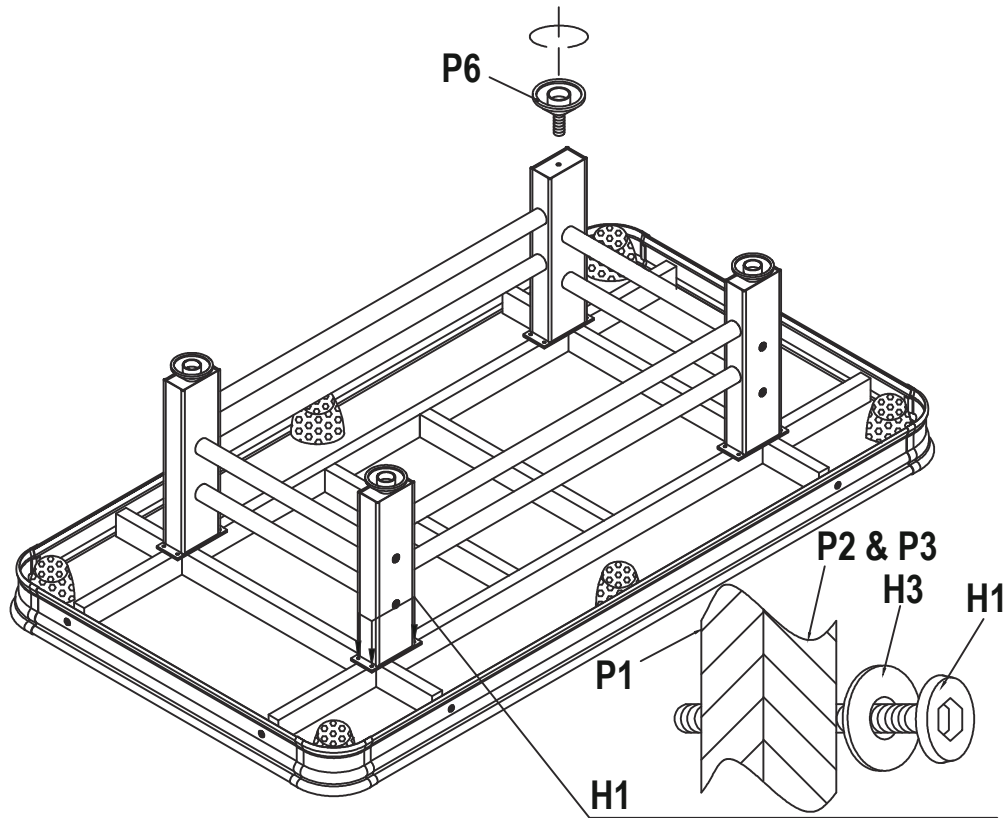

Step 4

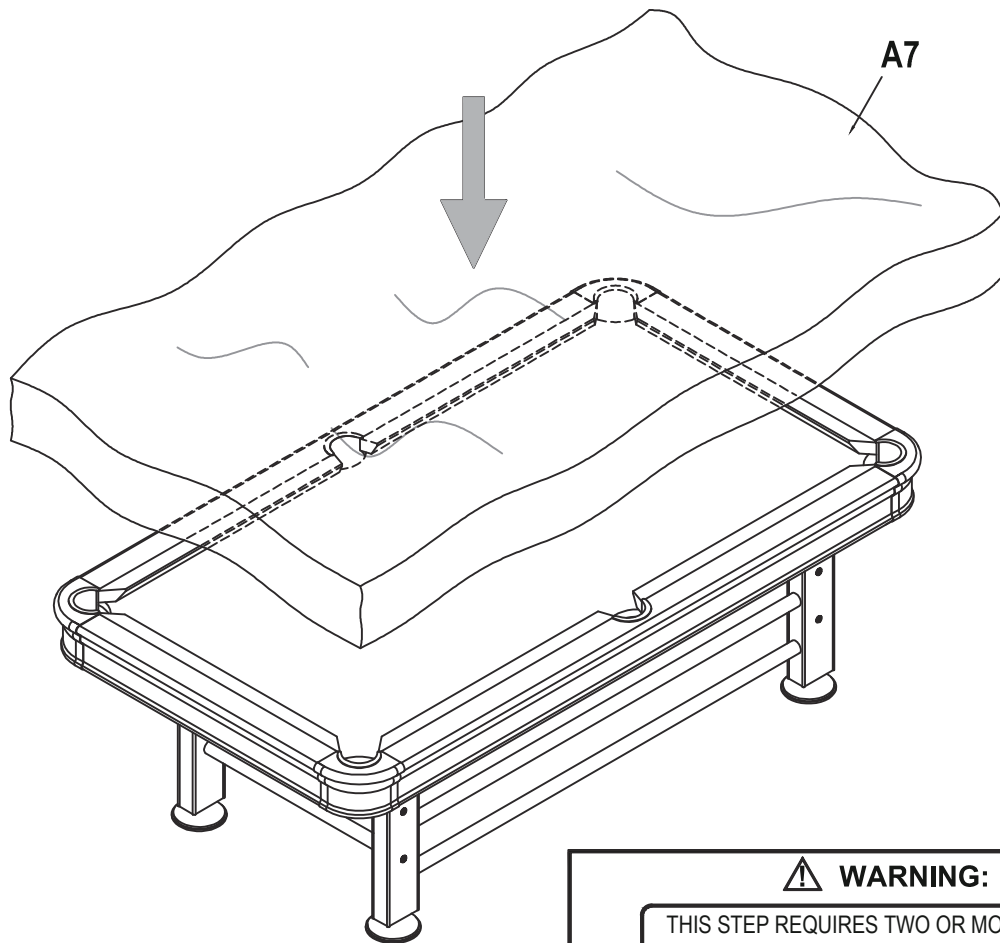

WARNING:

THIS STEP REQUIRES TWO OR MORE ADULTS.

VERY CAREFULLY TURN THE TABLE OVER AND SET IT ON ITS LEGS. DO NOT USE THE LEGS FOR LEVERAGE. BE CAREFUL, THE TABLE IS VERY HEAVY.

Turn the table over. Put the table in its final resting place. Using a carpenter's level, level the table by turning the leg levelers **P4**. Start by adjusting the lowest corner first and then work your way around the table.