

REVISION HISTORY				
REV.	DESCRIPTION	DATE	ECO	BY
A	RELEASED FOR PRODUCTION	1/8/2021		adold

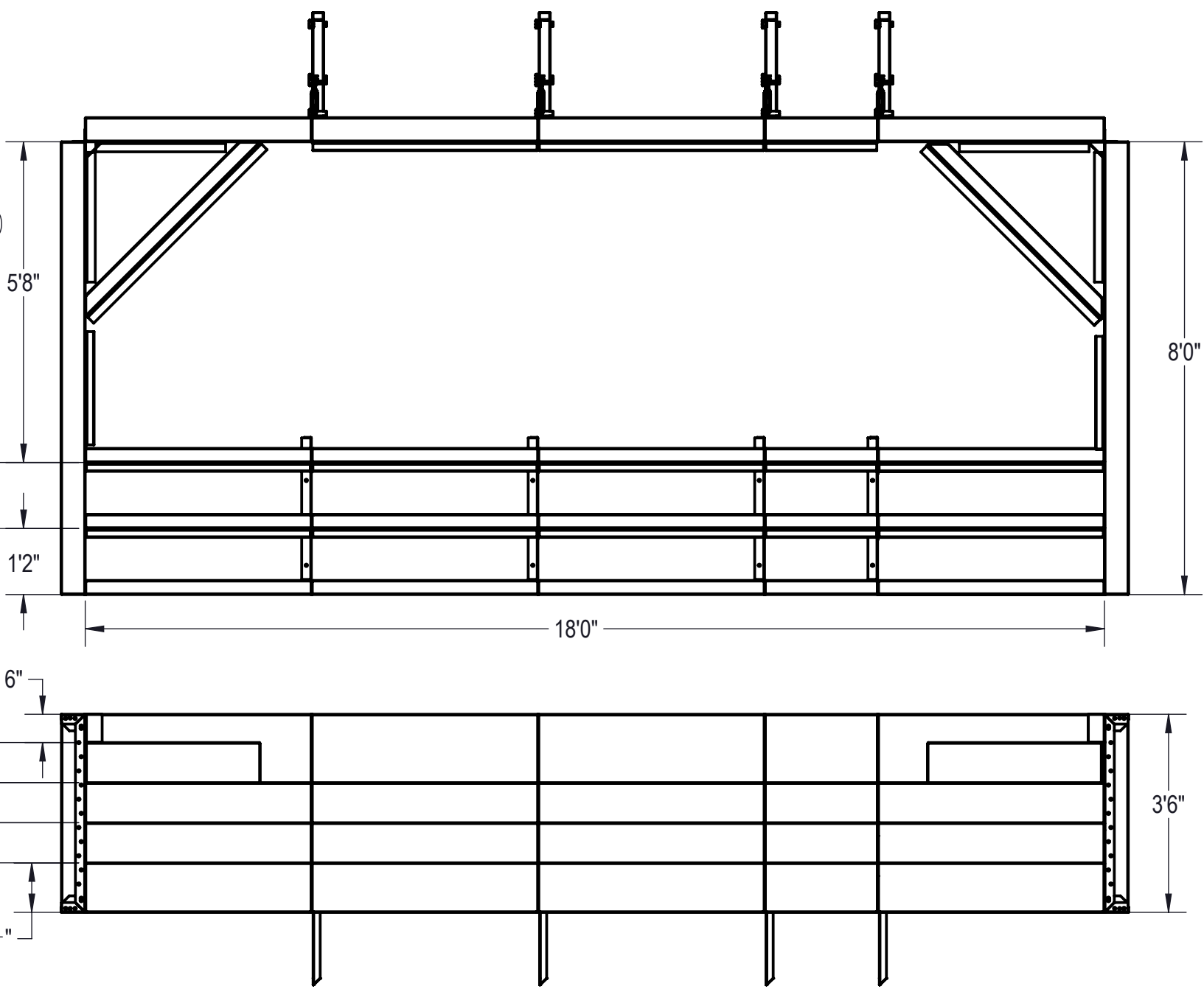
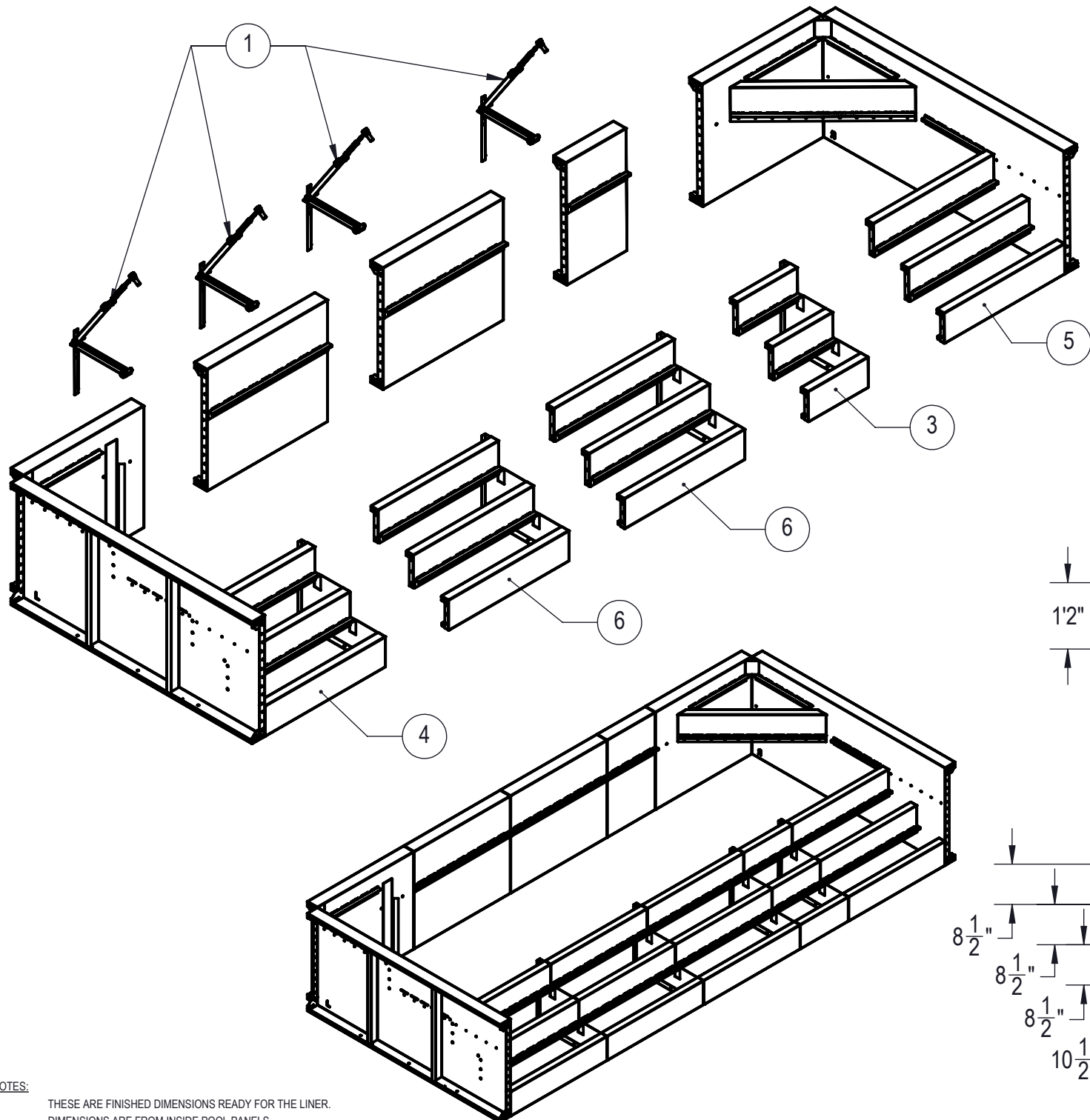

NOTES:

- THESE ARE FINISHED DIMENSIONS READY FOR THE LINER.
- DIMENSIONS ARE FROM INSIDE POOL PANELS.
- ROPE AND FLOAT ASSEMBLY SHOULD BE INSTALLED IN ACCORDANCE WITH CURRENT ANSI/ASPS/ICC REGULATIONS
- HYDRA LINER TRACK FOR STEPS IS INSTALLED WITH THE BARB FACING THE RISER WALL ON THE STEP.

EXCAVATION NOTES:

- ROUGH EXCAVATION SHOULD BE 2" DEEPER IN EACH INSTANCE.
- SOIL TO HAVE MINIMUM BEARING CAPACITY OF 1500 PSF.
- LOCATE TOP OF POOL AT LEAST 6" ABOVE THE SURROUNDING LAND ELEVATION.
- SEE "OVER DIG DETAIL" FOR EXCAVATION AROUND POOL.
- FILL VOIDS UNDER BASE OF PANELS AND TAMP WELL.
- BACK FILL WITH NON-EXPANSIVE MATERIAL.
- FOLLOW ALL CURRENT ANSI / A P S P / ICC GUIDELINES FOR RESIDENTIAL POOLS

IMPORTANT NOTES:

THIS DOCUMENT IS FOR ILLUSTRATIVE PURPOSES ONLY. THE DEALER OR CONTRACTOR WHO SELLS OR INSTALLS YOUR POOL IS AN INDEPENDENT CONTRACTOR AND IS NOT AN AGENT OF THE MANUFACTURER. THE CONSTRUCTION METHODS ILLUSTRATED HERE ARE SUGGESTIONS AND APPLY ONLY TO NORMAL GROUND CONDITIONS. THERE MAY BE ADDITIONAL PRECAUTIONS AND/OR METHODS OF CONSTRUCTION. PROPER INSTALLATION IS THE RESPONSIBILITY OF THE DEALER/BUILDER/CONTRACTOR.

ITEM	FILE NAME	DESCRIPTION	CUSTOMER DRAWING #	VENDOR PART #	QTY.
1	HPSFOB	ASSEMBLY, FOLD OVER BRACE, WITH TURNBUCKLE	HPSFOB		4
2	BOLT_PACK	BOLT, FLANGE, 3/8-16 X 1", PACK (50)	HPS1916	HPS1916	4
3	00034582	STEP, CORNER TOP TREAD, 2" X 8", 6" RADIUS, 4 TREAD, 4 SECTION, OPEN POUR, TANNING LEDGE, SUB ASSEMBLY	HSSM34582	00034582	1
4	00034416	STEP, CORNER TOP TREAD, 4" X 8", 6" RADIUS, 4 TREAD, 4 SECTION, OPEN POUR, TANNING LEDGE, SUB ASSEMBLY	HSSM34416	00034416	1
5	00034502	STEP, CORNER TOP TREAD, 4" X 8", 6" RADIUS, 4 TREAD, 4 SECTION, OPEN POUR, TANNING LEDGE, SUB ASSEMBLY	HSSM34502	00034502	1
6	00034420	STEP, CORNER TOP TREAD, 4" X 8", 6" RADIUS, 4 TREAD, 4 SECTION, OPEN POUR, TANNING LEDGE, SUB ASSEMBLY	HSSM34420	00034420	2

ENGINEERING DRAWING NUMBER 00034592	WEIGHT: lbs	UNLESS OTHERWISE SPECIFIED DIMENSIONS ARE IN INCHES TOLERANCES DECIMALS: X ± XX ± XXX ± XXXX ± ANGULAR: X ± 0.5 THIRD ANGLE PROJECTION	DESIGNED BY: ADOLD	CREATION DATE: 1/8/2021	SAMSON STEEL
	VOLUME: Inch ³		DETAILED DATE: 1/8/2021		
	COLOR:		LAST REVISED BY: adold	LAST REVISED DATE: 1/8/2021	
	HEAT TREAT:		MATERIAL:		
FINISH:					TITLE: STEP, CORNER TOP TREAD, 8' X 18', 6" RADIUS, 4 TREAD, OPEN POUR, 5'8" TANNING LEDGE, ASSEMBLY
TEXTURE:					PART NUMBER: 00034592
					SCALE: 1:32 SHEET: 1 OF 5 SIZE: B

REVISION HISTORY				
REV.	DESCRIPTION	DATE	ECO	BY
A	RELEASED FOR PRODUCTION	12/22/2020		adold

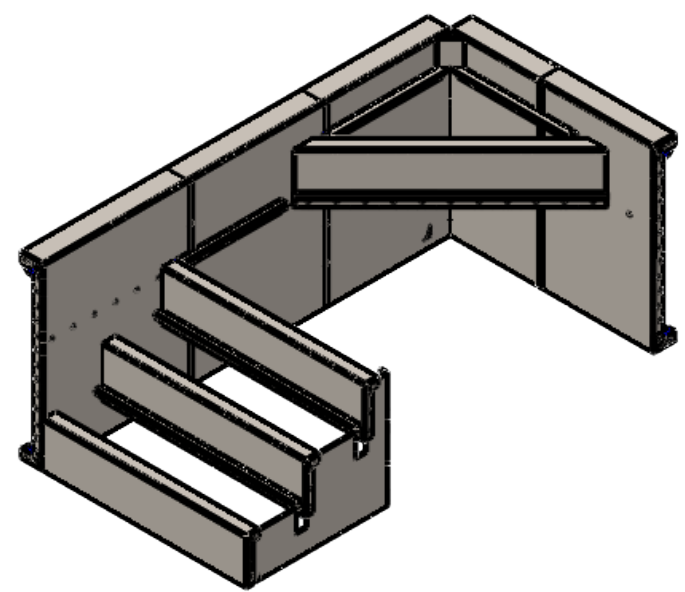
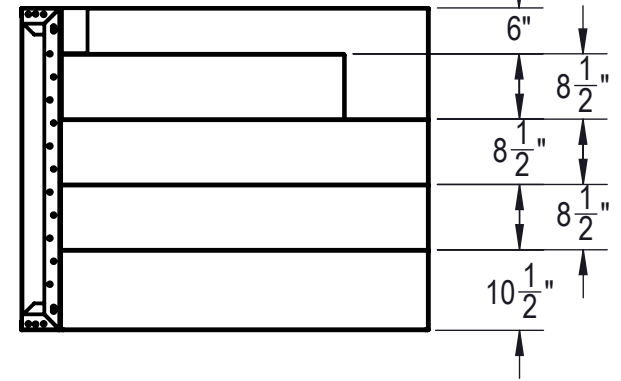
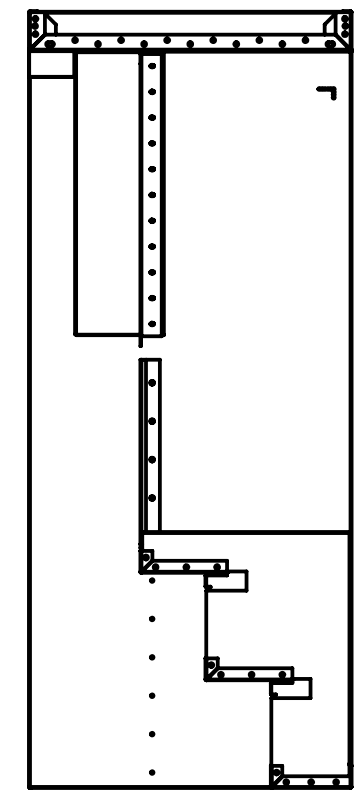
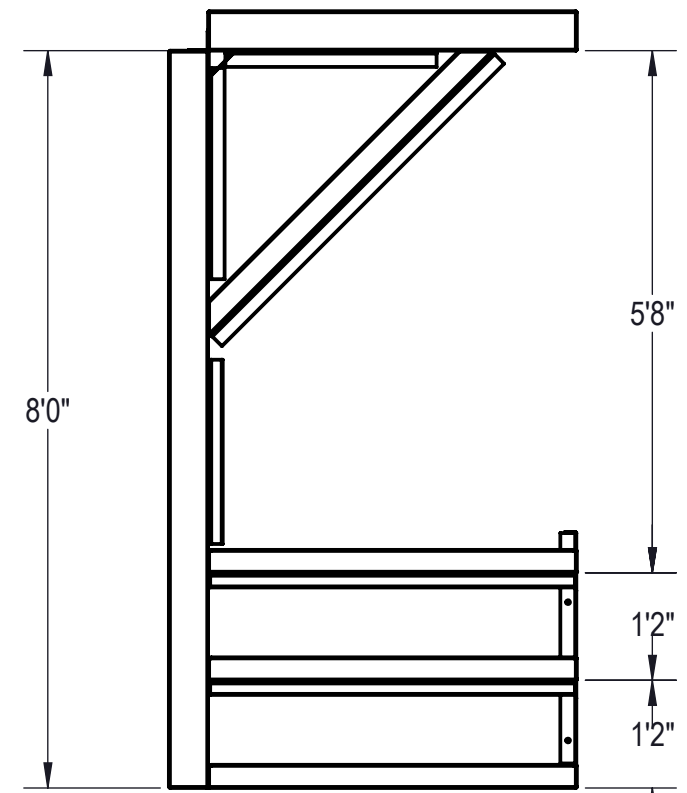
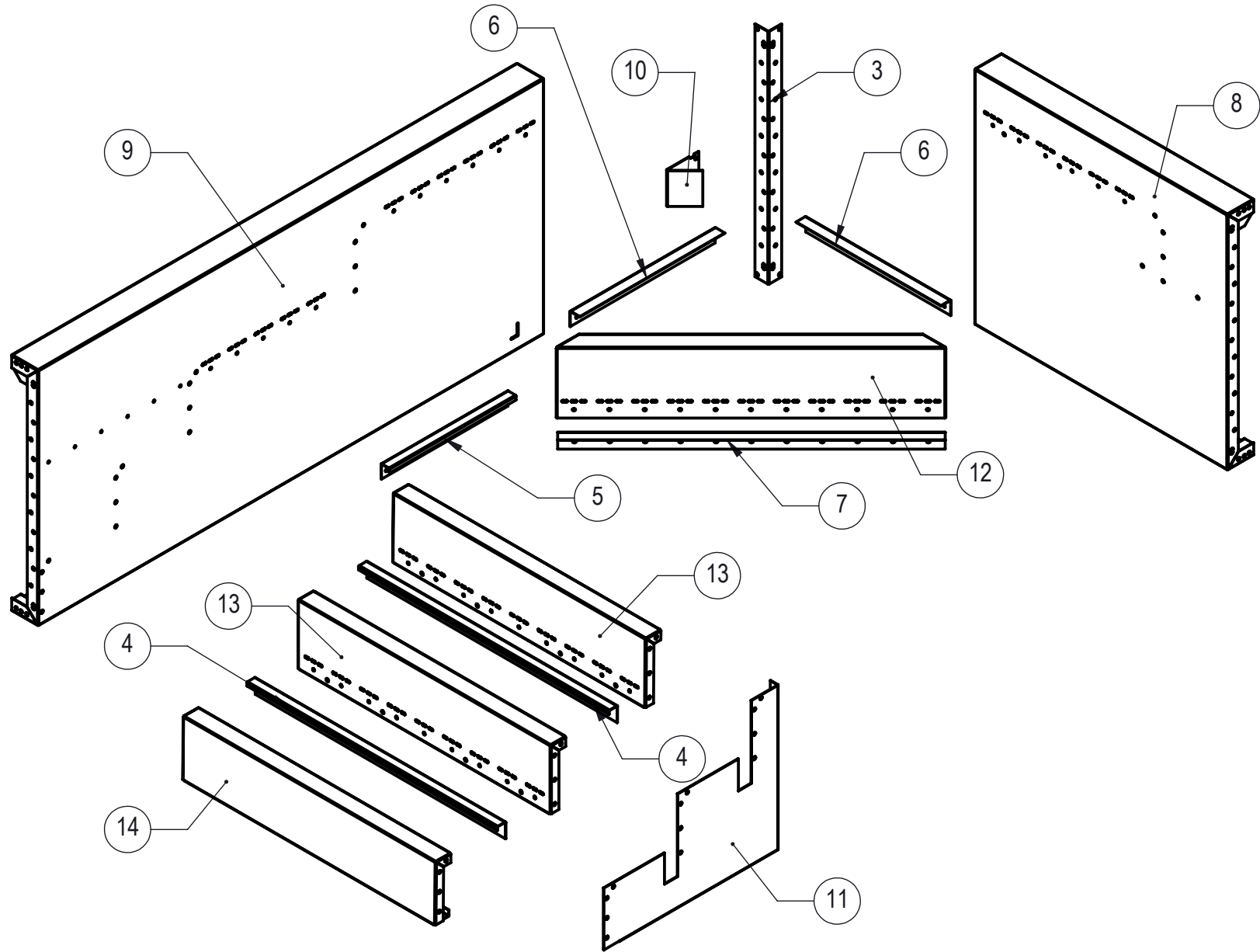

NOTES:

- THESE ARE FINISHED DIMENSIONS READY FOR THE LINER.
 - DIMENSIONS ARE FROM INSIDE POOL PANELS.
 - ROPE AND FLOAT ASSEMBLY SHOULD BE INSTALLED IN ACCORDANCE WITH CURRENT ANSI/ASPS/ICC REGULATIONS
 - HYDRA LINER TRACK FOR STEPS IS INSTALLED WITH THE BARB FACING THE RISER WALL ON THE STEP.
- EXCAVATION NOTES:**
- ROUGH EXCAVATION SHOULD BE 2" DEEPER IN EACH INSTANCE.
 - SOIL TO HAVE MINIMUM BEARING CAPACITY OF 1500 PSF.
 - LOCATE TOP OF POOL AT LEAST 6" ABOVE THE SURROUNDING LAND ELEVATION.
 - SEE "OVER DIG DETAIL" FOR EXCAVATION AROUND POOL.
 - FILL VOIDS UNDER BASE OF PANELS AND TAMP WELL.
 - BACK FILL WITH NON-EXPANSIVE MATERIAL.
 - FOLLOW ALL CURRENT ANSI / A P S P / ICC GUIDELINES FOR RESIDENTIAL POOLS

IMPORTANT NOTES:

THIS DOCUMENT IS FOR ILLUSTRATIVE PURPOSES ONLY. THE DEALER OR CONTRACTOR WHO SELLS OR INSTALLS YOUR POOL IS AN INDEPENDENT CONTRACTOR AND IS NOT AN AGENT OF THE MANUFACTURER. THE CONSTRUCTION METHODS ILLUSTRATED HERE ARE SUGGESTIONS AND APPLY ONLY TO NORMAL GROUND CONDITIONS. THERE MAY BE ADDITIONAL PRECAUTIONS AND/OR METHODS OF CONSTRUCTION. PROPER INSTALLATION IS THE RESPONSIBILITY OF THE DEALER/BUILDER/CONTRACTOR.

ITEM	FILE NAME	DESCRIPTION	CUSTOMER DRAWING #	VENDOR PART #	QTY.
1	BOLT, PACK	BOLT, FLANGE, 3/8-16 X 1", PACK (50)	HPS1916	HPS1916	2
2	SBRACE	BRACE, FOLD OVER WITH TURNBUCKLE, STEEL, HPSFOB	HPSF0B	HPSF0B	1
3	00000051	CONNECTOR, CORNER, 2 1/2" X 1 1/2" X 90°	HPSD90C	HPSD90C	1
4	00017122	LINER TRACK, OPEN POUR	00017122	00017122	2
5	00034424	LINER TRACK, RIGHT OR LEFT, 28"	00034424	00034424	1
6	00028268	LINER TRACK, TREAD "A"	00028268	00028268	2
7	00028269	LINER TRACK, TREAD "B"	00028269	00028269	1
8	00034418	PANEL BACK, LEFT, 4' LONG, 4 TREAD, OPEN POUR, CORNER FIRST STEP, TANNING LEDGE, ASSEMBLY	00034418	00034418	1
9	00034419	PANEL, STEP, 4 TREAD, BENCH, LEFT SIDE, OPEN POUR, BENCH OPTION, ASSEMBLY	00034419		1
10	00010294	STEP, 4 TREAD, 90 DEGREE, CORNER, 6" RADIUS FILLER, FITS 10269			1
11	00034413	SUPPORT, CENTER, 4 TREAD, OPEN POUR	00034413	00034413	1
12	00034425	TREAD, STEP, 4 TREAD, CORNER, TREAD "A", OPEN POUR	00034425	00034425	1
13	00034411	TREAD, STEP, 4 TREAD, OPEN POUR, "B", 4"	00034411	00034411	2
14	00034412	TREAD, STEP, 4 TREAD, OPEN POUR, "C", 4' LONG	00034412	00034412	1

ENGINEERING DRAWING NUMBER 00034416	WEIGHT: lbs	UNLESS OTHERWISE SPECIFIED DIMENSIONS ARE IN INCHES TOLERANCES DECIMALS: X ± XX ± XXX ± XXXX ± ANGLAR: X ± 0.5 THIRD ANGLE PROJECTION 	DESIGNED BY: ADOLD	CREATION DATE: 1/9/2018	SAMSON STEEL TITLE: STEP, CORNER TOP TREAD, 4' X 8', 6" RADIUS, 4 TREAD, LEFT, OPEN POUR, TANNING LEDGE, SUB ASSEMBLY PART NUMBER: HSSM34416			
	VOLUME: Inch ³		DETAILED BY: adold	DETAILED DATE: 1/8/2021				
	COLOR: NA		HEAT TREAT: NA	FINISH: NA		TEXTURE: 576	LAST REVISED BY: adold	LAST REVISED DATE: 1/8/2021
	MATERIAL:		SCALE: 1:32			SIZE: B		

REVISION HISTORY				
REV.	DESCRIPTION	DATE	ECO	BY
A	RELEASED FOR PRODUCTION	12/22/2020		adold

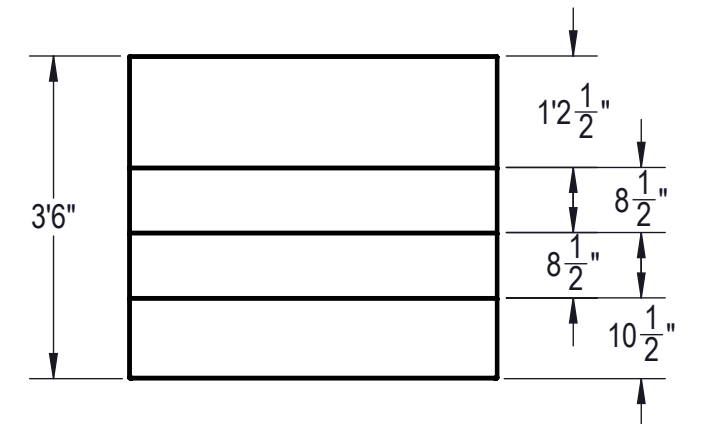
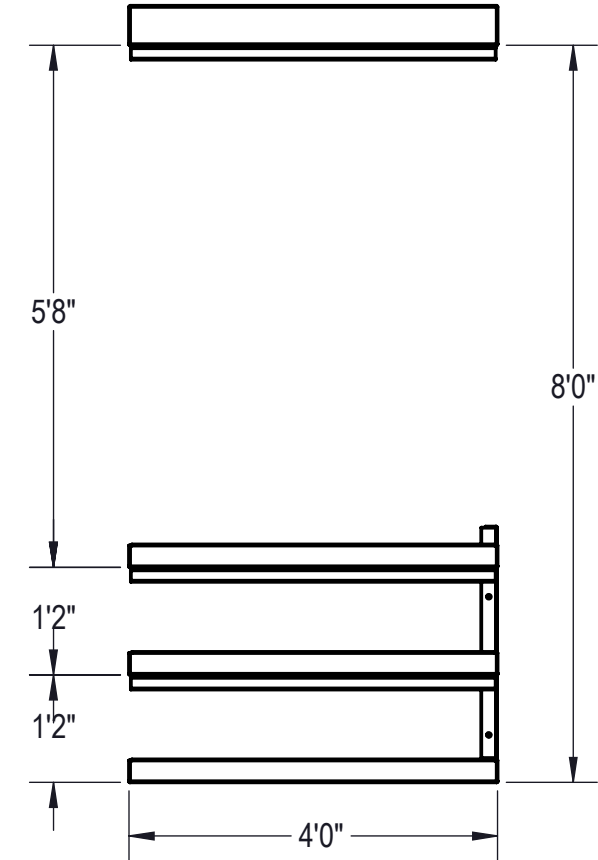
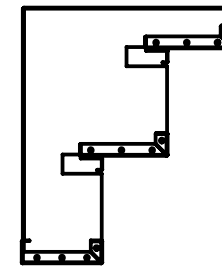
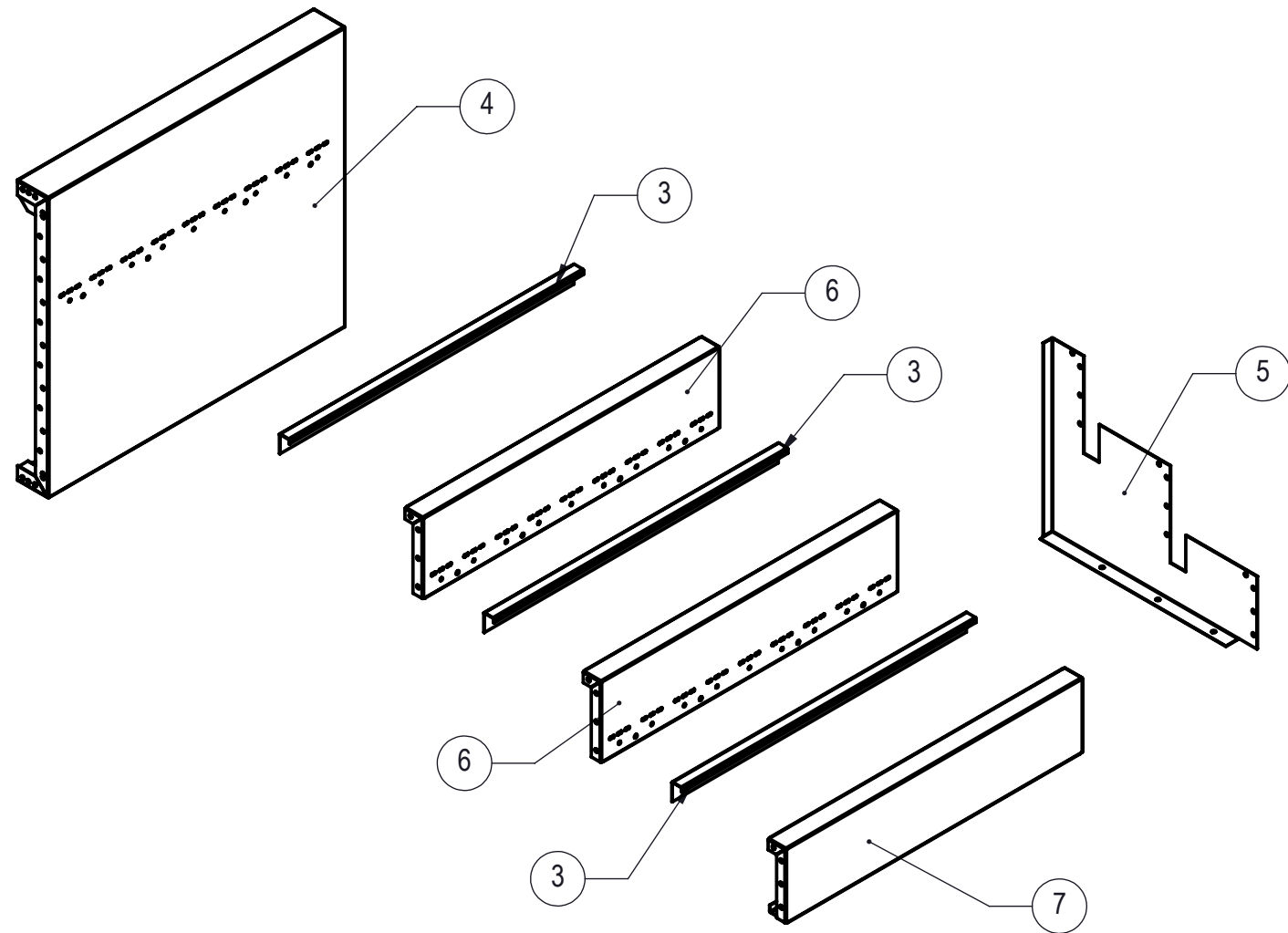

NOTES:

- THESE ARE FINISHED DIMENSIONS READY FOR THE LINER.
- DIMENSIONS ARE FROM INSIDE POOL PANELS.
- ROPE AND FLOAT ASSEMBLY SHOULD BE INSTALLED IN ACCORDANCE WITH CURRENT ANSI/APSP/ICC REGULATIONS
- HYDRA LINER TRACK FOR STEPS IS INSTALLED WITH THE BARB FACING THE RISER WALL ON THE STEP.

EXCAVATION NOTES:

- ROUGH EXCAVATION SHOULD BE 2" DEEPER IN EACH INSTANCE.
- SOIL TO HAVE MINIMUM BEARING CAPACITY OF 1500 PSF.
- LOCATE TOP OF POOL AT LEAST 6" ABOVE THE SURROUNDING LAND ELEVATION.
- SEE "OVER DIG DETAIL", IN INSTALLATION MANUAL, FOR EXCAVATION AROUND POOL.
- FILL VOIDS UNDER BASE OF PANELS AND TAMP WELL.
- BACK FILL WITH NON-EXPANSIVE MATERIAL.
- FOLLOW ALL CURRENT ANSI / APSP / ICC GUIDELINES FOR RESIDENTIAL POOLS

IMPORTANT NOTES:

THIS DOCUMENT IS FOR ILLUSTRATIVE PURPOSES ONLY. THE DEALER OR CONTRACTOR WHO SELLS OR INSTALLS YOUR POOL IS AN INDEPENDENT CONTRACTOR AND IS NOT AN AGENT OF THE MANUFACTURER. THE CONSTRUCTION METHODS ILLUSTRATED HERE ARE SUGGESTIONS AND APPLY ONLY TO NORMAL GROUND CONDITIONS. THERE MAY BE ADDITIONAL PRECAUTIONS AND/OR METHODS OF CONSTRUCTION. PROPER INSTALLATION IS THE RESPONSIBILITY OF THE DEALER/BUILDER/CONTRACTOR.

ITEM	FILE NAME	DESCRIPTION	CUSTOMER DRAWING #	VENDOR PART #	QTY.
1	BOLT, PACK	BOLT, FLANGE, 3/8-16 X 1", PACK (50)	HPS1916	HPS1916	2
2	SBRACE	BRACE, FOLD OVER WITH TURNBUCKLE, STEEL, HPSFOB	HPSFOB	HPSFOB	1
3	00017122	LINER TRACK, OPEN POUR	00017122	00017122	3
4	00034441	PANEL BACK, 4' LONG, 4 TREAD, OPEN POUR, TANNING LEDGE ASSEMBLY	00034441	00034418	1
5	00034413	SUPPORT, CENTER, 4 TREAD, OPEN POUR	00034413	00034413	1
6	00034411	TREAD, STEP, 4 TREAD, OPEN POUR, "B", 4'	00034411	00034411	2
7	00034412	TREAD, STEP, 4 TREAD, OPEN POUR, "C", 4' LONG	00034412	00034412	1

ENGINEERING DRAWING NUMBER 00034420	WEIGHT: lbs	UNLESS OTHERWISE SPECIFIED DIMENSIONS ARE IN INCHES TOLERANCES DECIMALS: X ± XX ± XXX ± XXXX ± ANGULAR: X ± 0.5 THIRD ANGLE PROJECTION	DESIGNED BY: ADOLD	CREATION DATE: 1/9/2018	SAMSON STEEL
	VOLUME: Inch ³		DETAILED BY: adold	DETAILED DATE: 1/8/2021	
	COLOR: NA		LAST REVISED BY: adold	LAST REVISED DATE: 1/8/2021	
	HEAT TREAT: NA		MATERIAL:		
FINISH: NA			TITLE: STEP, CORNER TOP TREAD, 4' X 8', 6" RADIUS, 4 TREAD, 4' SECTION, OPEN POUR, TANNING LEDGE, SUB ASSEMBLY		
TEXTURE: 576			PART NUMBER: HSSM34420		
			SCALE: 1:32		
			SHEET: 3 OF 5		
			B		

REVISION HISTORY				
REV.	DESCRIPTION	DATE	ECO	BY
A	RELEASED FOR PRODUCTION	1/8/2021		adold

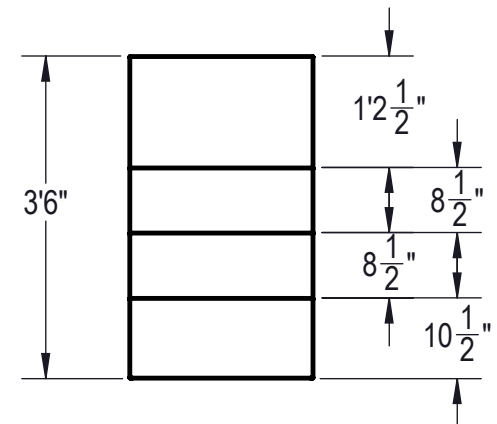
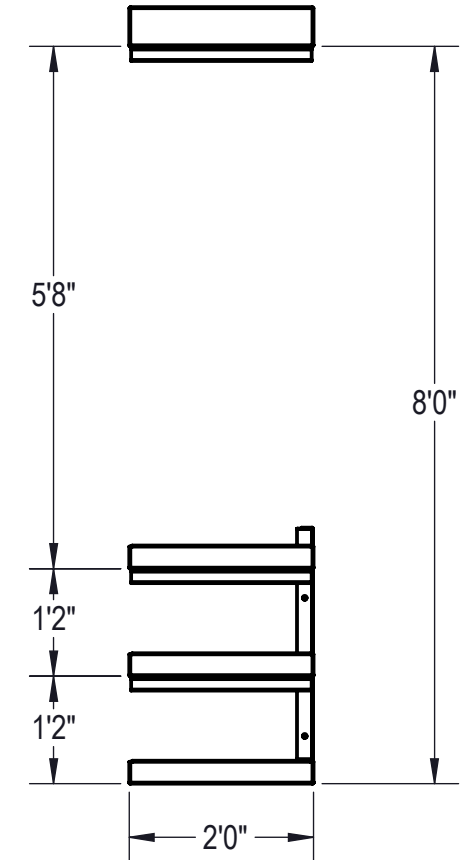
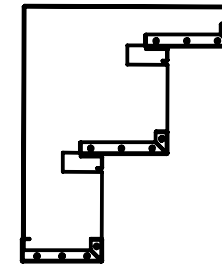
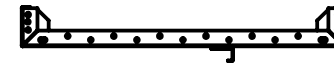
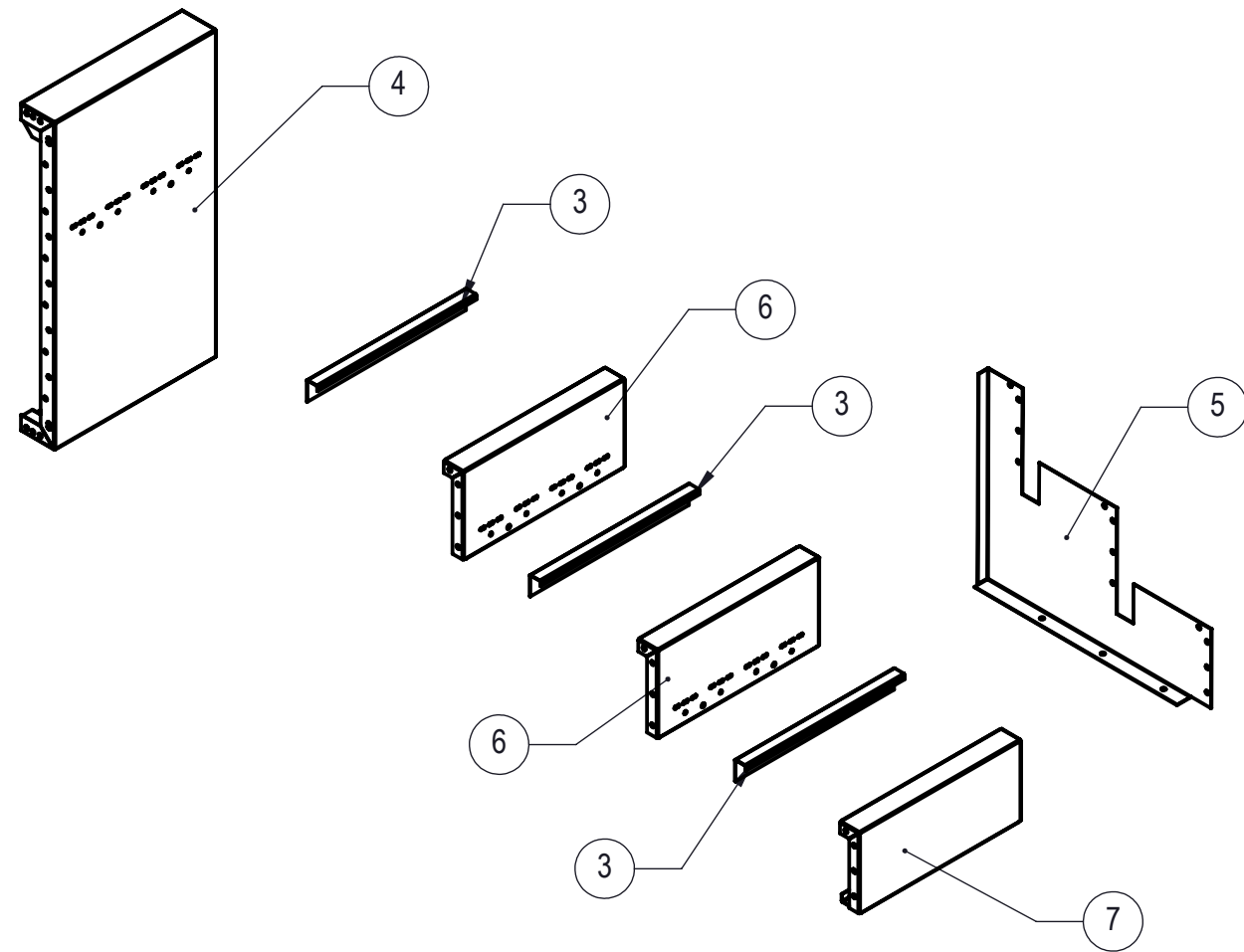

NOTES:

- THESE ARE FINISHED DIMENSIONS READY FOR THE LINER.
- DIMENSIONS ARE FROM INSIDE POOL PANELS.
- ROPE AND FLOAT ASSEMBLY SHOULD BE INSTALLED IN ACCORDANCE WITH CURRENT ANSI/APSP/ICC REGULATIONS
- HYDRA LINER TRACK FOR STEPS IS INSTALLED WITH THE BARB FACING THE RISER WALL ON THE STEP.

EXCAVATION NOTES:

- ROUGH EXCAVATION SHOULD BE 2" DEEPER IN EACH INSTANCE.
- SOIL TO HAVE MINIMUM BEARING CAPACITY OF 1500 PSF.
- LOCATE TOP OF POOL AT LEAST 6" ABOVE THE SURROUNDING LAND ELEVATION.
- SEE "OVER DIG DETAIL", IN INSTALLATION MANUAL, FOR EXCAVATION AROUND POOL.
- FILL VOIDS UNDER BASE OF PANELS AND TAMP WELL.
- BACK FILL WITH NON-EXPANSIVE MATERIAL.
- FOLLOW ALL CURRENT ANSI / APSP / ICC GUIDELINES FOR RESIDENTIAL POOLS

IMPORTANT NOTES:

THIS DOCUMENT IS FOR ILLUSTRATIVE PURPOSES ONLY. THE DEALER OR CONTRACTOR WHO SELLS OR INSTALLS YOUR POOL IS AN INDEPENDENT CONTRACTOR AND IS NOT AN AGENT OF THE MANUFACTURER. THE CONSTRUCTION METHODS ILLUSTRATED HERE ARE SUGGESTIONS AND APPLY ONLY TO NORMAL GROUND CONDITIONS. THERE MAY BE ADDITIONAL PRECAUTIONS AND/OR METHODS OF CONSTRUCTION. PROPER INSTALLATION IS THE RESPONSIBILITY OF THE DEALER/BUILDER/CONTRACTOR.

ITEM	FILE NAME	DESCRIPTION	CUSTOMER DRAWING #	VENDOR PART #	QTY.
1	BOLT, PACK	BOLT, FLANGE, 3/8-16 X 1", PACK (50)	HPS1916	HPS1916	2
2	SBRACE	BRACE, FOLD OVER WITH TURNBUCKLE, STEEL, HPSFOB	HPSFOB	HPSFOB	1
3	00013551	LINER TRACK, BACK, FITS 13547	00013551	00013551	3
4	00034577	PANEL BACK, 2' LONG, 4' TREAD, OPEN POUR, CORNER FIRST TREAD, TANNING LEDGE, ASSEMBLY			1
5	00034413	SUPPORT, CENTER, 4 TREAD, OPEN POUR	00034413	00034413	1
6	00034579	TREAD, STEP, 4 TREAD, OPEN POUR, "B", 2'	00034579	00034579	2
7	00034581	TREAD, STEP, 4 TREAD, OPEN POUR, "C", 2' LONG	00034581	00034581	1

ENGINEERING DRAWING NUMBER 00034582	WEIGHT: lbs	UNLESS OTHERWISE SPECIFIED DIMENSIONS ARE IN INCHES TOLERANCES DECIMALS: X ± XX ± XXX ± XXXX ± ANGULAR: X ± 0.5 THIRD ANGLE PROJECTION 	DESIGNED BY: ADOLD	CREATION DATE: 1/9/2018	SAMSON STEEL
	VOLUME: Inch ³		DETAILED BY: adold	DETAILED DATE: 1/8/2021	
	COLOR: NA		LAST REVISED BY: adold	LAST REVISED DATE: 1/8/2021	
	HEAT TREAT: NA		MATERIAL:		
FINISH: NA				TITLE: STEP, CORNER TOP TREAD, 2' X 8', 6" RADIUS, 4 TREAD, 4' SECTION, OPEN POUR, TANNING LEDGE, SUB ASSEMBLY	
TEXTURE: 576				PART NUMBER: HSSM34582	
					SCALE: 1:32 SHEET: 4 OF 5 SIZE: B

REVISION HISTORY				
REV.	DESCRIPTION	DATE	ECO	BY
A	RELEASED FOR PRODUCTION	1/5/2021		adol

CHECK IN DATE/TIME: Friday, January 08, 2021 11:02:59 AM

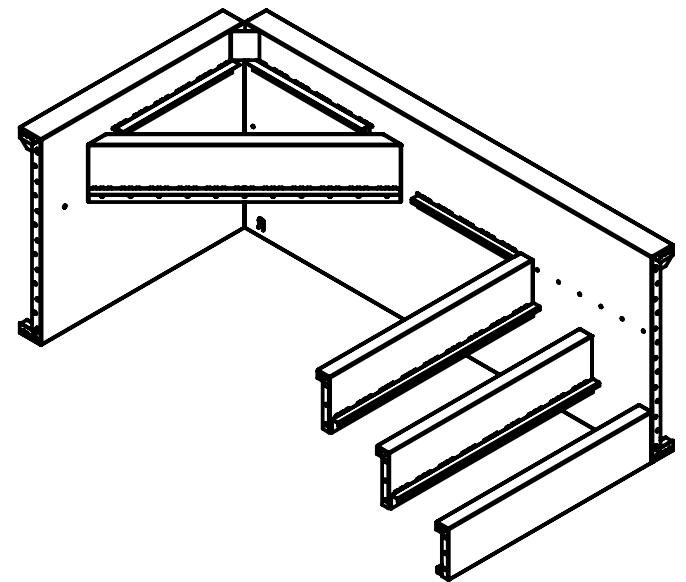
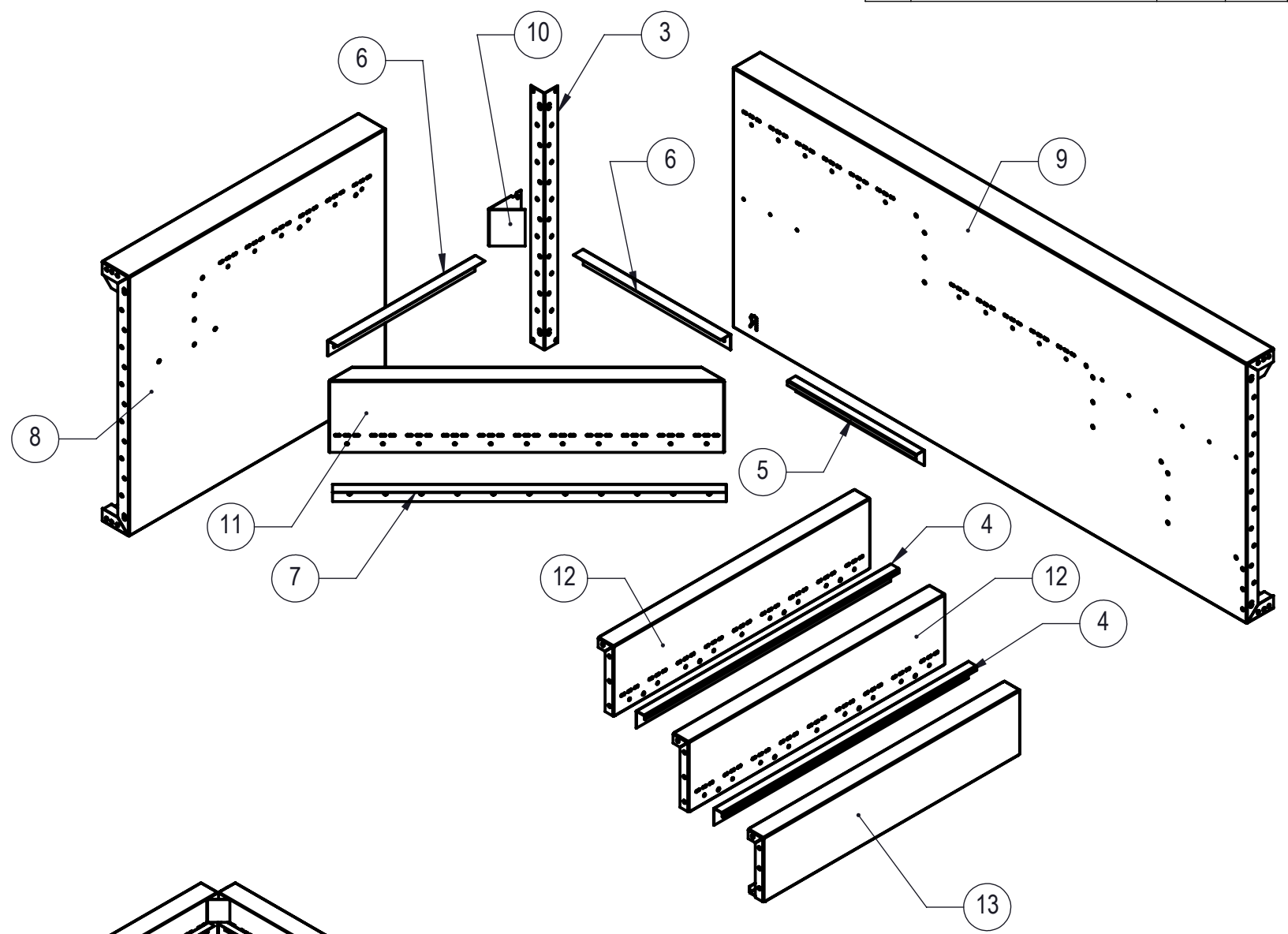
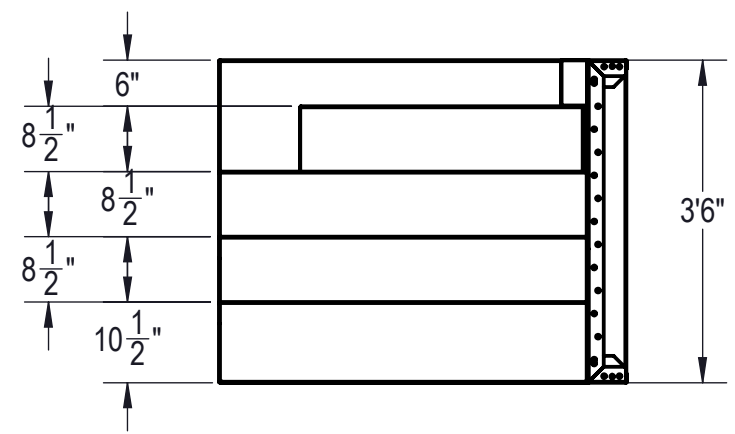
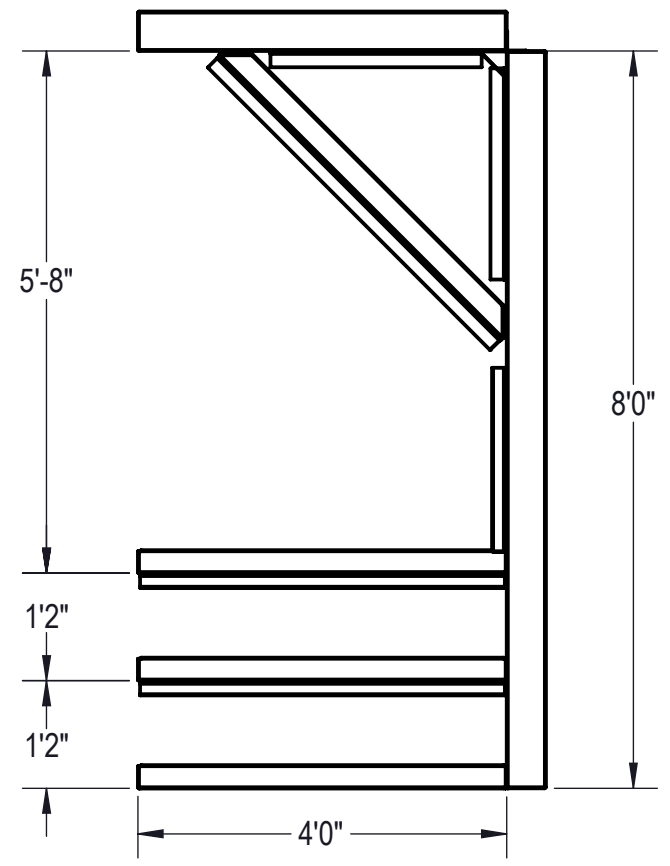
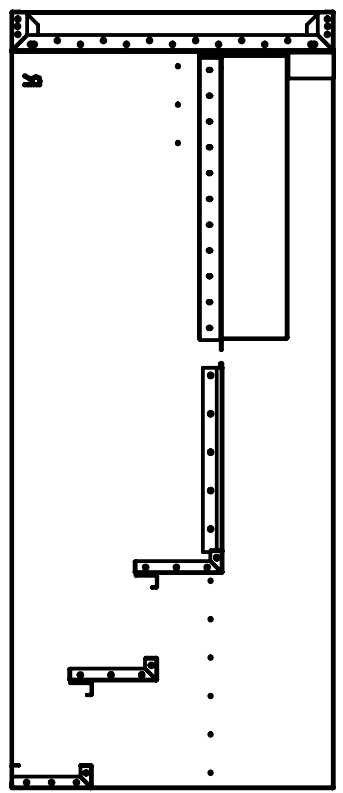

NOTES:

- THESE ARE FINISHED DIMENSIONS READY FOR THE LINER.
- DIMENSIONS ARE FROM INSIDE POOL PANELS.
- ROPE AND FLOAT ASSEMBLY SHOULD BE INSTALLED IN ACCORDANCE WITH CURRENT ANSI/ASPS/ICC REGULATIONS
- HYDRA LINER TRACK FOR STEPS IS INSTALLED WITH THE BARB FACING THE RISER WALL ON THE STEP.

EXCAVATION NOTES:

- ROUGH EXCAVATION SHOULD BE 2" DEEPER IN EACH INSTANCE.
- SOIL TO HAVE MINIMUM BEARING CAPACITY OF 1500 PSF.
- LOCATE TOP OF POOL AT LEAST 6" ABOVE THE SURROUNDING LAND ELEVATION.
- SEE "OVER DIG DETAIL" FOR EXCAVATION AROUND POOL.
- FILL VOIDS UNDER BASE OF PANELS AND TAMP WELL.
- BACK FILL WITH NON-EXPANSIVE MATERIAL.
- FOLLOW ALL CURRENT ANSI / APSP / ICC GUIDELINES FOR RESIDENTIAL POOLS

IMPORTANT NOTES:

THIS DOCUMENT IS FOR ILLUSTRATIVE PURPOSES ONLY. THE DEALER OR CONTRACTOR WHO SELLS OR INSTALLS YOUR POOL IS AN INDEPENDENT CONTRACTOR AND IS NOT AN AGENT OF THE MANUFACTURER. THE CONSTRUCTION METHODS ILLUSTRATED HERE ARE SUGGESTIONS AND APPLY ONLY TO NORMAL GROUND CONDITIONS. THERE MAY BE ADDITIONAL PRECAUTIONS AND/OR METHODS OF CONSTRUCTION. PROPER INSTALLATION IS THE RESPONSIBILITY OF THE DEALER/BUILDER/CONTRACTOR.

ITEM	FILE NAME	DESCRIPTION	CUSTOMER DRAWING #	VENDOR PART #	QTY.
1	BOLT, PACK	BOLT, FLANGE, 3/8-16 X 1", PACK (50)	HPS1916	HPS1916	2
2	SBRACE	BRACE, FOLD OVER WITH TURNBUCKLE, STEEL, HPSFOB	HPSFOB	HPSFOB	1
3	00000051	CONNECTOR, CORNER, 2 1/2" X 1 1/2" X 90°	HPSD90C	HPSD90C	1
4	00017122	LINER TRACK, OPEN POUR	00017122	00017122	2
5	00034424	LINER TRACK, RIGHT OR LEFT, 28"	00034434	00034434	1
6	00028268	LINER TRACK, TREAD "A"	00028268	00028268	2
7	00028269	LINER TRACK, TREAD "B"	00028269	00028269	1
8	00034503	PANEL BACK, RIGHT, 4' LONG, 4 TREAD, OPEN POUR, TANNING LEDGE, ASSEMBLY	00034503	00034503	1
9	00034501	PANEL, STEP, 4 TREAD, CORNER BENCH, MID LEDGE, RIGHT SIDE, OPEN POUR, ASSEMBLY	00034501	00028527	1
10	00010294	STEP, 4 TREAD, 90 DEGREE, CORNER, 6" RADIUS FILLER, FITS 10289			1
11	00034425	TREAD, STEP, 4 TREAD, CORNER, TREAD "A", OPEN POUR	00034425	00034425	1
12	00034411	TREAD, STEP, 4 TREAD, OPEN POUR, "B", 4"	00034411	00034411	2
13	00034412	TREAD, STEP, 4 TREAD, OPEN POUR, "C", 4' LONG	00034412	00034412	1

ENGINEERING DRAWING NUMBER 00034502	WEIGHT: lbs VOLUME: Inch ³	UNLESS OTHERWISE SPECIFIED DIMENSIONS ARE IN INCHES TOLERANCES DECIMALS: X ± XX ± XXX ± XXXX ± ANGLAR: X ± 0.5 THIRD ANGLE PROJECTION	DESIGNED BY: ADOLD DETAILED DATE: adol 1/8/2021 LAST REVISED BY: adol 1/8/2021 MATERIAL:	CREATION DATE: 1/9/2018 LAST REVISED DATE: 1/8/2021	SAMSON STEEL TITLE: STEP, CORNER TOP TREAD, 4' X 8', 6" RADIUS, 4 TREAD, RIGHT, OPEN POUR, TANNING LEDGE, SUB ASSEMBLY
	COLOR: NA HEAT TREAT: NA FINISH: NA TEXTURE: 576	PART NUMBER: HSSM34502	SCALE: 1:32 SHEET: 5 OF 5	SIZE: B	